



SwimClear™ CARTRIDGE FILTER

Owner's Manual

Models C100S, C150S and C275S



Contents

Product Specific Warnings.....	2
Introduction.....	4
Installation.....	4
Operation & Maintenance.....	5
Replacement Parts.....	7
Warranty & Registration	8

IMPORTANT SAFETY INSTRUCTIONS

Basic safety precautions should always be followed: failure to follow instructions can cause severe injury and/or death.

⚠ This is the safety-alert symbol. When you see this symbol on your equipment or in this manual, look for one of the following signal words and be alert to the potential for personal injury.

⚠ WARNING warns about hazards that **can** cause serious personal injury, death or major property damage and if ignored presents a potential hazard.

⚠ CAUTION warns about hazards that **will** or **can** cause minor or moderate personal injury and/or property damage and if ignored present a potential hazard. It can also make consumers aware of actions that are unpredictable and unsafe.

The **NOTICE** label indicates special instructions that are important but not related to hazards.

SAVE THIS INSTRUCTION MANUAL

Hayward Industries
 1415 Vantage Park Dr., Suite 400
 Charlotte, NC 28203
 Phone (908)-355-7995
www.hayward.com



⚠ WARNING – Read, understand and follow all instructions in this owner’s manual and on the equipment. Failure to follow instructions can cause severe injury and/or death.

⚠ WARNING – Suction Entrapment Hazard.

Suction in suction outlets and/or suction outlet covers which are, damaged, broken, cracked, missing, or unsecured can cause severe injury and/or death due to the following entrapment hazards:



Hair Entrapment- Hair can become entangled in suction outlet cover.



Limb Entrapment- A limb inserted into an opening of a suction outlet sump or suction outlet cover that is damaged, broken, cracked, missing, or not securely attached can result in a mechanical bind or swelling of the limb.



Body Suction Entrapment- A negative pressure applied to a large portion of the body or limbs can result in an entrapment.



Evisceration/ Disembowelment - A negative pressure applied directly to the intestines through an unprotected suction outlet sump or suction outlet cover which is, damaged, broken, cracked, missing, or unsecured can result in evisceration/ disembowelment.

Mechanical Entrapment- There is potential for jewelry, swimsuits, hair decorations, fingers, toes or knuckles to be caught in an opening of a suction outlet cover resulting in mechanical entrapment.

⚠ WARNING - To Reduce the risk of Entrapment Hazards:

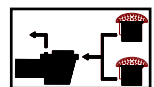

- When outlets are small enough to be blocked by a person, a minimum of two functioning suction outlets per pump must be installed. Suction outlets in the same plane (i.e. floor or wall), must be installed a minimum of three feet (3') [1 meter] apart, as measured from near point to near point.
- Dual suction fittings shall be placed in such locations and distances to avoid “dual blockage” by a user.
- Dual suction fittings shall not be located on seating areas or on the backrest for such seating areas.
- The maximum system flow rate shall not exceed the flow rating as listed on the suction outlet cover.
- Never use Pool or Spa if any suction outlet component is damaged, broken, cracked, missing, or not securely attached.
- Replace damaged, broken, cracked, missing, or not securely attached suction outlet components immediately.
- In addition, two or more suction outlets per pump installed in accordance with latest ASME, APSP Standards and CPSC guidelines, follow all National, State, and Local codes applicable.
- Installation of a vacuum release or vent system, which relieves entrapping suction, is recommended.

⚠ WARNING – Failure to remove pressure test plugs and/or plugs used in winterization of the pool/spa from the suction outlets can result in an increased potential for suction entrapment as described above.

⚠ WARNING – Failure to keep suction outlet components clear of debris, such as leaves, dirt, hair, paper and other material can result in an increase potential for suction entrapment as described above.

⚠ WARNING – Suction outlet components have a finite life: the cover/grate should be inspected frequently and replaced at least every seven years or if found to be damaged, broken, cracked, missing, or not securely attached.

⚠ CAUTION – Components such as the filtration system, pumps and heater must be positioned so as to prevent their being used as means of access to the pool by young children. To reduce risk of injury, do not permit children to use or climb on this product. Closely supervise children at all times. Components such as the filtration system, pumps, and heaters must be positioned to prevent children from using them as a means of access to the pool.



⚠ WARNING – Hazardous Pressure. Pool and spa water circulation systems operate under hazardous pressure during start up, normal operation, and after pump shut off. Stand clear of circulation system equipment during pump start up. Failure to follow safety and operation instructions could result in violent separation of the pump housing and cover, and/or filter housing and lock ring due to pressure in the system, which could cause property damage, severe personal injury, or death. Before servicing pool and spa water circulation system, all system and pump controls must be in off position and filter manual air relief valve must be in open position. Before starting system pump, all system valves must be set in a position to allow system water to return back to the pool. Do not change filter control valve position while system pump is running. Before starting system pump, fully open filter manual air relief valve. Do not close filter manual air relief valve until a steady stream of water (not air or air and water) is discharged.



⚠ WARNING – Separation Hazard. Failure to follow safety and operation instructions could result in violent separation of pump and/or filter components. Strainer cover must be properly secured to pump housing with strainer cover lock ring. Before servicing pool and spa circulation system, filters manual air relief valve must be in open position. Do not operate pool and spa circulation system if a system component is not assembled properly, damaged, or missing. **Never operate or test the circulation system at more than 50 PSI. Do not purge the system with compressed air.** Purging the system with compressed air can cause components to explode, with risk of severe injury or death to anyone nearby. Use only a low pressure (below 5 PSI), high volume blower when air purging the pump, filter, or piping.



HAYWARD®



⚠ WARNING – Risk of Electric Shock. All electrical wiring **MUST** be in conformance with applicable local codes, regulations, and the National Electric Code (NEC). Hazardous voltage can shock, burn, and cause death or serious property damage. To reduce the risk of electric shock, do **NOT** use an extension cord to connect unit to electric supply. Provide a properly located electrical receptacle. Before working on any electrical equipment, turn off power supply to the equipment. To reduce the risk of electric shock replace damaged wiring immediately. Locate conduit to prevent abuse from lawn mowers, hedge trimmers and other equipment. Do **NOT** ground to a gas supply line.

⚠ WARNING – Risk of Electric Shock. Failure to ground all electrical equipment can cause serious or fatal electrical shock hazard. Electrically ground all electrical equipment before connecting to electrical power supply.

⚠ WARNING – Risk of Electric Shock. Failure to bond all electrical equipment to pool structure will increase risk for electrocution and could result in injury or death. To reduce the risk of electric shock, see installation instructions and consult a professional electrician on how to bond all electrical equipment. Also, contact a licensed electrician for information on local electrical codes for bonding requirements.

Notes to electrician: Use a solid copper conductor, size 8 or larger. Run a continuous wire from external bonding lug to reinforcing rod or mesh. Connect a No. 8 AWG (8.4 mm²) [No. 6 AWG (13.3 mm²) for Canada] solid copper bonding wire to the pressure wire connector provided on the electrical equipment and to all metal parts of swimming pool, spa, or hot tub, and metal piping (except gas piping), and conduit within 5 ft. (1.5 m) of inside walls of swimming pool, spa, or hot tub.

IMPORTANT - Reference NEC codes for all wiring standards including, but not limited to, grounding, bonding and other general wiring procedures.

⚠ WARNING – Risk of Electric Shock. The electrical equipment must be connected only to a supply circuit that is protected by a ground-fault circuit-interrupter (GFCI). Such a GFCI should be provided by the installer and should be tested on a routine basis. To test the GFCI, push the test button. The GFCI should interrupt power. Push reset button. Power should be restored. If the GFCI fails to operate in this manner, the GFCI is defective. If the GFCI interrupts power to the electrical equipment without the test button being pushed, a ground current is flowing, indicating the possibility of an electrical shock. Do not use this electrical equipment. Disconnect the electrical equipment and have the problem corrected by a qualified service representative before using.

⚠ CAUTION – HAYWARD® pumps are intended for use with permanently-installed pools and may be used with hot tubs and spas if so marked. Do not use with storable pools. A permanently-installed pool is constructed in or on the ground or in a building such that it cannot be readily disassembled for storage. A storable pool is constructed so that it is capable of being readily disassembled for storage and reassembled to its original integrity.

⚠ WARNING – Risk of Hyperthermia. To avoid hyperthermia the following “Safety Rules for Hot Tubs” are recommended by the U.S. Consumer Product Safety Commission.

1. Spa or hot tub water temperatures should never exceed 104°F [40°C]. A temperature of 100°F [38°C] is considered safe for a healthy adult. Special caution is suggested for young children. Prolonged immersion in hot water can induce hyperthermia.
2. Drinking of alcoholic beverages before or during spa or hot tub use can cause drowsiness, which could lead to unconsciousness and subsequently result in drowning.
3. Pregnant women beware! Soaking in water above 100°F [38°C] can cause fetal damage during the first three months of pregnancy (resulting in the birth of a brain-damaged or deformed child). Pregnant women should adhere to the 100°F [38°C] maximum rule.
4. Before entering the spa or hot tub, users should check the water temperature with an accurate thermometer; spa or hot tub thermostats may err in regulating water temperatures by as much as 4°F (2.2°C).
5. Persons taking medications, which induce drowsiness, such as tranquilizers, antihistamines or anticoagulants, should not use spas or hot tubs.
6. If the pool/spa is used for therapy, it should be done with the advice of a physician. Always stir pool/ spa water before entering the pool/spa to mix in any hot surface layer of water that might exceed healthful temperature limits and cause injury. Do not tamper with controls, because scalding can result if safety controls are not in proper working order.
7. Persons with a medical history of heart disease, circulatory problems, diabetes or blood pressure problems should obtain a physician’s advice before using spas or hot tubs.
8. Hyperthermia occurs when the internal temperature of the body reaches a level several degrees above normal body temperature of 98.6°F [37°C]. The symptoms of Hyperthermia include: drowsiness, lethargy, dizziness, fainting, and an increase in the internal temperature of the body.

The effects of Hyperthermia include:

1. Unawareness of impending danger.
2. Failure to perceive heat.
3. Failure to recognize the need to leave the spa.
4. Physical inability to exit the spa.
5. Fetal damage in pregnant women.
6. Unconsciousness resulting in danger of drowning.

SAVE THESE INSTRUCTIONS



GENERAL INFORMATION

The SwimClear filters are high performance swimming pool filters with a residential filtration rating of up to 7200 gallons (27 kL) per hour. Manufactured from durable, corrosion-proof material, they are designed for continuous or intermittent operation, for installation above or below the pool water line, for fresh or saltwater swimming pools or spas. SwimClear filters utilize a reusable single element, reinforced polyester filter cartridge to provide a high degree of water clarity with absolute minimum care. Their unique design is such that no tools are needed to remove or replace the cartridge in the filter assembly. Simply unscrew the lock ring, lift off the filter head and remove the cartridge. It's that easy.

PUMP SELECTION AND LOCATION

To power your SwimClear filter, select a continuous duty pump designed for swimming pool or spa service. It is important to first determine where your pump and filter will be located. If above the water line, a self-priming pump must be used. Self-priming pumps such as Hayward's Super Pump®, Super II™, or TriStar™ have the ability to lift water from a lower level and prime automatically.

Select a pump appropriate for your application. Take into consideration: operation of hydrotherapy fittings, automatic cleaners, required turnover rates and losses in the system. A dealer can help you select the proper size pump for you system.

FILTER LOCATION

1. Since plumbing fittings offer a resistance to water flow, position the filter as close to the swimming pool as local codes allow. Keep the number of fittings to a minimum. Select a well-drained area, one that will not flood when it rains.
2. Set the filter on a solid level surface. Allow a minimum clearance above the body for cartridge removal of 12" (305mm) for the C100S and allow 15" (381mm) for the C150S and allow 18" (457mm) for the C275S. Observe minimum side clearance requirements for the filter, and pump (see fig.3). Locate drain, air relief and pressure gauge for convenient operation and viewing.
3. Position the filter to allow for proper drainage.
4. If practical, place pump and filter in the shade to shield it from direct heat from the sun.

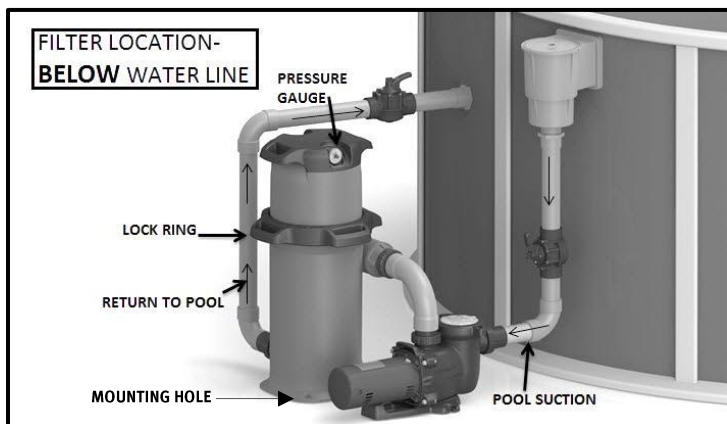

Fig. 1

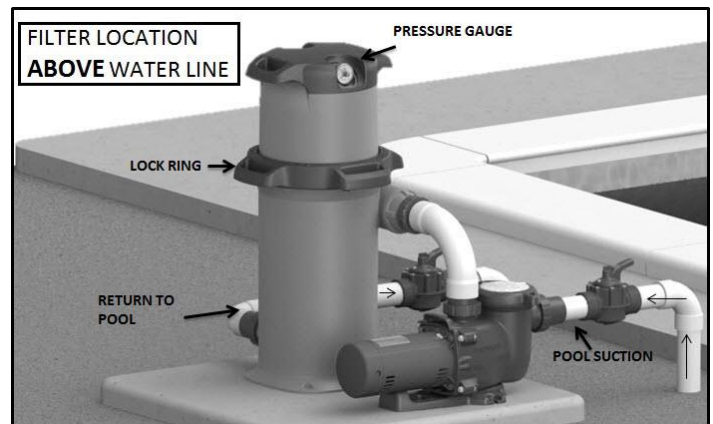

Fig. 2

PLUMBING

1. The union fittings included with the SwimClear are 2" x 2 1/2" union sockets (solvent weld). The 2" union fitting is a pipe socket connection. For 2 1/2" piping, a standard 2 1/2" x 2 1/2" coupling is required. For 1 1/2" socket fittings order SPX1500JS. For 1 1/2" threaded fittings order SPX1500JT. **Before solvent cementing fitting onto pipe, do not forget to place the union nut on the pipe with the threads facing the filter. Proper Solvent Cementing practices as outlined in ASTM D2855 and ASTM F493 should be followed.**
2. Refer to fig.1 and 2 for basic suggested piping and valve locations. While systems vary, the main consideration is to provide the desired control of water flow from the pool to the pump and filter, and back to the pool. When the filter is located below water level, provide valves to prevent back flow of water to the filter during cleaning and routine servicing.
3. Install face seal, then screw the union nut on to the body to connect the filter to the pump. This connection is the one above the pump discharge
4. Install face seal, then screw the union nut on to the body to connect the filter to the return pool plumbing.
5. Carefully replace cartridge element into filter body ensuring that the cartridge sits evenly on the collector hub in bottom of filter body.
6. Place filter head on filter body (being sure filter head o-ring is in place and clean).
7. Tighten lock ring (in clockwise direction) until safety latch fully engages the catch.



8. A 1 1/2" NPT filter drain plug is furnished with each filter. When making threaded connections to the filter use plastic adapters. Apply three turns of PTFE tape (or use special plastic pipe sealant) to male threads. Screw the fitting into the thread hand tight; then using a strap wrench, tighten one more full turn. Additional tightening is unnecessary and could result in broken or damaged valve body.
9. A manual air relief valve is furnished to aid in bleeding off unwanted air when starting the filter.
10. All electrical connections should be made in accordance with local codes.
11. Check for joint leaks before operating.
12. Refer to pump instruction booklet for pump information.

	REQUIRED CLEARANCE			
	SIDE		ABOVE	
	IN	CM	IN	CM
C100S	12	30	12	30
C150S	12	30	15	38
C275S	12	30	18	45

Fig. 3

FILTER MOUNTING

Secure filter to level concrete slab or other rigid surface to meet all local and national codes. Use fasteners appropriate for the material of the surface being fastened to. Use 2 of the 4 available mounting holes (see fig.1) on opposite corners of the filter base to ensure the filter is secure and level.

▲ CAUTION: Be careful not to over tighten the fasteners when mounting the filter. Failure to do so may cause the base of the filter to crack at the mounting locations causing the filter to be unstable.

STARTING THE FILTER

Be sure filter drain is closed. Open manual air relief valve and open the suction and return valves (when used).

▲ CAUTION: All suction and discharge valves must be open when starting the system. Failure to do so could cause severe personal injury and/or property damage. Be sure lock ring is locked and in latched position.

Stand clear of the filter. Prime and start the pump, following the manufacturer's instructions. Air trapped in the system will automatically vent to the pool and out the manual air relief valve. Close the air relief valve when a steady stream of water (not air or air and water) is being discharged.

FILTERING

Filtration starts as soon as flow is steady through the filter. As the filter cartridge removes dirt from the pool water, the accumulated dirt causes a resistance to flow. As a result, the gauge pressure will increase and flow will decrease. When the indicated pressure increases 7 to 10 psi (0.49 to 0.70 Bar) above the starting pressure, or when flow decreases below the desired filtration rate, clean or replace the filter cartridge.

CLEAN / REPLACE CARTRIDGE

REMOVING CARTRIDGE ELEMENT

1. Shut off the pump.
2. If filter is located below water level, close valves or block off suction & discharge lines to prevent backflow of water from the pool.
3. Remove drain plug and open the manual air relief valve to allow water to drain from filter.
4. Depress safety latch and unscrew the lock ring (counterclockwise direction). Carefully lift off filter head with the attached lock ring to gain access to filter cartridge. (Set Head on a flat surface on top of the handle)
5. Lift out cartridge and clean or, replace with a clean, spare cartridge. (See Cleaning Cartridge.)
6. Clean body o-ring in filter head.

REINSTALLING CARTRIDGE ELEMENT

1. Clean any collected debris from the bottom of filter body. Clean the Body o-ring seal area.
2. Carefully replace cartridge element into filter body ensuring that the cartridge sits evenly on the collector hub in bottom of filter body.
3. Place filter head on filter body (being sure filter head o-ring is in place and clean).
4. Tighten lock ring (in clockwise direction) until safety latch fully engages the catch.
5. Proceed as in **STARTING THE FILTER**.



CLEANING CARTRIDGE

The cartridge filter element can be cleaned by washing inside and out with a garden hose. (The cartridge is easier to clean when dry.) After hosing the cartridge, for best results, allow cartridge to dry and carefully brush pleated surface areas to remove fine particles. **Do not pressure wash, as it can damage the filter element.**

To remove materials such as suntan and body oils from the cartridge pleats, soak the element in a solution of filter element cleaner (various brands available at pool dealer). Follow manufacturer's directions for use and allow an hour for soaking. Hose thoroughly before reinstalling in filter.

⚠ CAUTION: Be sure to use a plastic container and take extreme care when handling cleaning agents as they can be harmful to eyes, skin and clothing. After cleaning flush with water.

NON-CHLORINE POOLS

Cartridges used in pools or spas that use Baquacil® Sanitizer or other similar non-chlorine based products must be cleaned more frequently than when used in pools that utilize a chlorine system. Consult manufacturer's instructions for frequency, instructions, and chemicals required for cleaning elements in these types of systems. Baquacil® is not compatible with chlorine, bromine, any copper based chemical or non-chlorine shock.

A spare cartridge filter element is an excellent investment. It provides convenience and ensures that your filter will always be ready to operate at peak efficiency.

VACUUMING

Vacuuming can be performed directly into the filter whenever needed. Clean cartridge after vacuuming, if required.

WINTERIZING (Filter)

In areas where sub-freezing temperatures can be expected, the filter should be drained and/or removed from it's operating location and stored indoors. Remove and clean cartridge. Reinstall cartridge in filter tank. Fully tighten lock ring when storing.

SERVICE AND REPAIRS

Consult your local authorized Hayward dealer or service center. No returns may be made directly to the factory without the expressed written authorization of Hayward Pool Products.

MODEL	EFFECTIVE FILTRATION AREA		DESIGN FLOW RATE RESIDENTIAL		DESIGN FLOW RATE PUBLIC	
	FT ²	M ²	GPM	LPM	GPM	LPM
C100S	100	10.8	100	410	37	140
C150S	150	13.9	120	454	56	212
C275S	275	25.6	200	757	100	410
MAXIMUM WORKING PRESSURE FOR ALL MODELS 50 PSI (3.45 BAR)						

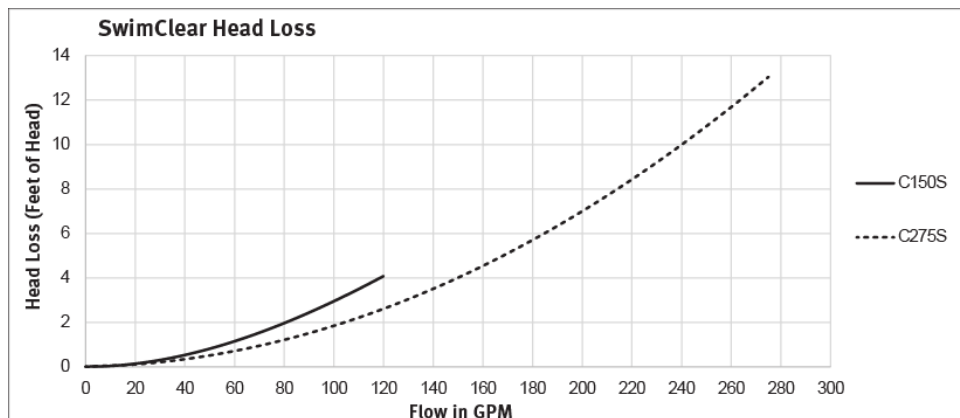

PARTS
Models C100S, C150S and C275S

REF NO.	PART NO.	DESCRIPTION	NO. REQ'D.
1	ECX271261	Pressure Gauge	1
2	CCX1000L	Threaded Adapter for Pressure Gauge	1
3	CXRLV1001	Air Relief Assembly with O-Ring	1
4	CXGAR1001Pak2	O-Ring for Gauge Adapter and Air Relief Assembly (set of 2)	1
5	CCX1000N	Adapter Nut (set of 2)	2
6a	CX100B	Filter Head Assembly C100S	1
6b	CX150B	Filter Head Assembly C150S	1
6c	CX200B	Filter Head Assembly C275S	1
7	CXLRL1001	Latch for Lock Ring	1
8	CXFHR1001	O-Ring for Filter Head	1
9a	CX100XRE	Cartridge Element C100S	1
9b	CX150XRE	Cartridge Element C150S	1
9c	CX275XRE	Cartridge Element C275S	1
10	CXFBA1001	Filter Body Assembly	1
11a	CXFDA100	Filter Diffuser Assembly C100S	1
11b	CXFDA150	Filter Diffuser Assembly C150S	1
11c	CXFDA200	Filter Diffuser Assembly C275S	1
12	SP1022CBLK	Drain Plug with O-Ring	1
13	SPX3200UNKIT	Union Connection Kit (2 each of Nuts, Connectors, and Gaskets)	1
	OPTIONAL		
	SPX1500JS	Union Connector 1.5" Socket	1
	SPX1500JT	Union Connector 1.5" NPTF	1

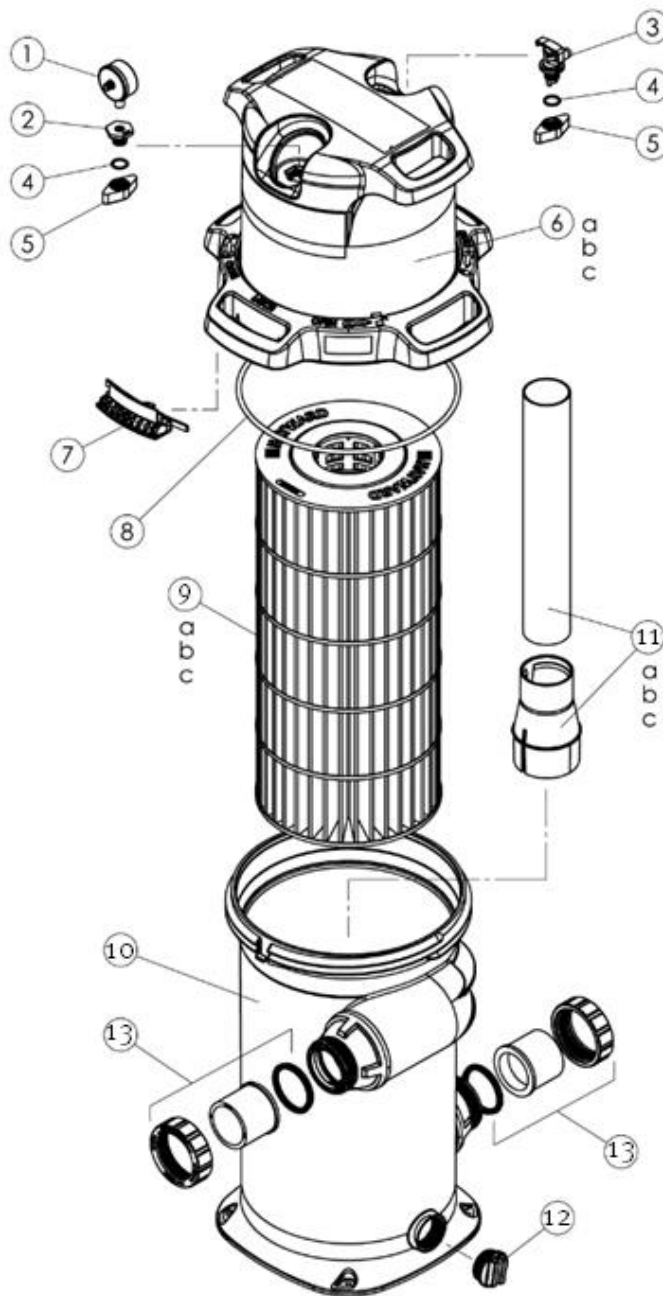



PRODUCT REGISTRATION

DATE OF INSTALLATION _____

(Retain For Your Records)

▲ Retain this Warranty Certificate in a safe and convenient location for your records

For warranty information, visit our website at <https://hayward.com/support/resources/warranty>



Hayward and SwimClear are registered trademarks of Hayward Industries, Inc.
All other trademarks not owned by Hayward are the property of their respective owners. Hayward is not in any way affiliated with or endorsed by those third parties. For patent information, refer to www.hayward.com/patents.
© 2026 Hayward Industries, Inc.