

HIGH PERFORMANCE HEAVY DUTY, SUPER SAVINGS.

Super II ECO[®] 0.75hp

Single Speed Pump

Built to last and engineered
to perform under the
most demanding
conditions.



 **HAYWARD**[®]

We Build Better.™

Super II ECO®

Single Speed Pump

PERFORMANCE
OF A LIFETIME.

- **Heavy duty, high performance motor** with advanced airflow ventilation for quieter, cooler operation.
- **Full flow hydraulics** allow a greater flow at a lower operational cost.
- **Simple access** - the motor and entire drive group assembly can be removed, without disturbing pipe or mounting connections by disengaging just six bolts.
- **Warranty:** 2 years + 1 year if purchased from a Totally Hayward Partner.

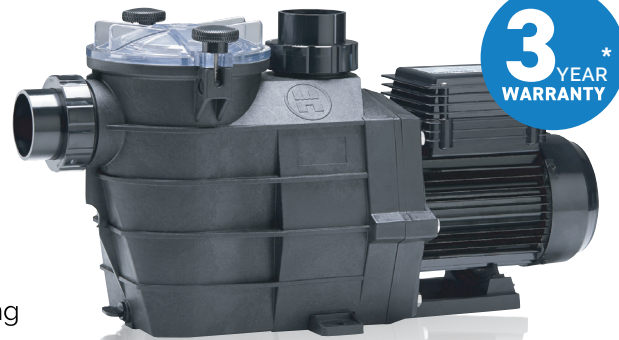

Flow Charts

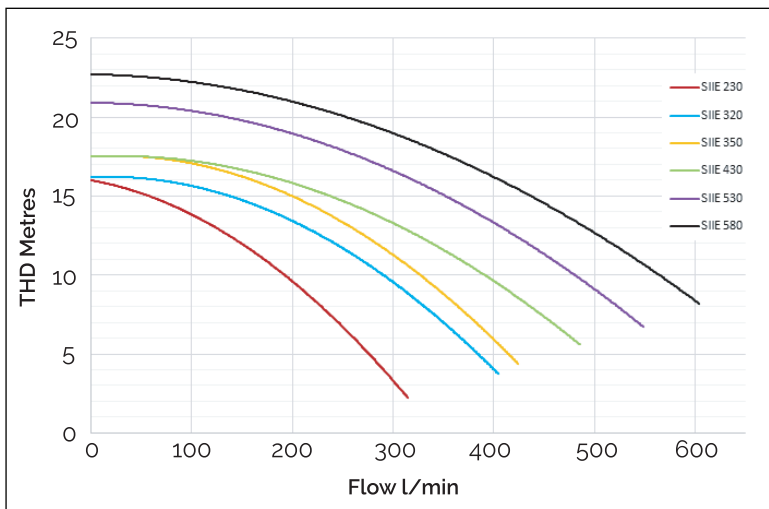

Dimensions

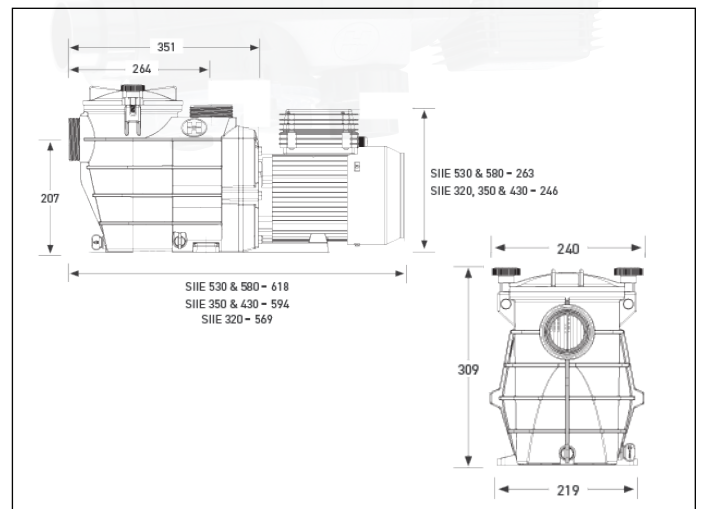

MODEL NUMBER	INGRESS PROTECTION	MAX INPUT POWER (KW)	INPUT AMPS	HP	LENGTH x WIDTH (mm)	PVC PIPE (mm)	NOISE DB (A)@1M	WEIGHT (Kg)
SIIIE 230	IPX5	0.74	3.3	0.75	569 X 240	40/50	< 70	12.5
SIIIE 320	IPX5	0.98	4.34	1	569 X 240	40/50	< 70	13.4
SIIIE 350	IPX5	1.1	5.1	1.25	594 X 240	40/50	< 70	15.3
SIIIE 430	IPX5	1.38	6.23	1.5	594 X 240	40/50	< 70	15.3
SIIIE 530	IPX5	1.86	8.33	2	618 X 240	40/50	< 70	19.05
SIIIE 580	IPX5	2.33	10.46	3	618 X 240	40/50	< 70	20.8