



# S-LINE HEAT PUMP RANGE



## HEAT PUMP UNIT

### Installation & Operation Manual

To prevent potential injury and to avoid unnecessary service calls, read this manual carefully and completely. Retain and ensure this manual is passed on to the end user.

Hayward Pool Products (Australia) Pty Ltd. Melbourne-Sydney-Brisbane-Perth  
Email: [sales@hayward-pool.com.au](mailto:sales@hayward-pool.com.au) | Website: [www.hayward-pool.com.au](http://www.hayward-pool.com.au)  
PO Box 4384 | Dandenong South VIC 3164  
ABN 66 083 413 414 Sales  
Contact Ph: 1300POOLS1 Fax: 1300POOLS2



# CONTENTS

1. Preface	1
2. Specifications	4
2.1 Performance Data of Swimming Pool Heat Pump Unit	4
2.2 Dimensions for Swimming Pool Heat Pump Unit	5
3. Installation and Connection	9
3.1 Installation illustration	9
3.2 Swimming Pool Heat Pumps Location	10
3.3 How Close to Your Pool?	10
3.4 Swimming Pool Heat Pumps Plumbing	11
3.5 Swimming Pool Heat Pumps Electrical Wiring	12
3.6 Initial Start-up of the Unit	13
4. Use and Operation Instruction of Wire Controller	14
4.1 Interface display	14
4.2 Key and icon function instruction	14
4.3 Parameter list and breakdown table	25
4.4 Interface drawing	27
5. Use and Operation Instruction of WIFI module	32
6. Maintenance and Inspection	39
7. Appendix	44
7.1 Caution & Warning	44
7.2 Cable specification	45
7.3 Comparison table of refrigerant saturation temperature	46
7.4 Exploded view and spare parts	47

# 1. PREFACE

---

- In order to provide our customers with quality, reliability and versatility, this product has been made to strict production standards. This manual includes all the necessary information about installation, debugging, discharging and maintenance. Please read this manual carefully before you open or maintain the unit. The manufacture of this product will not be held responsible if someone is injured or the unit is damaged, as a result of improper installation, debugging, or unnecessary maintenance. It is vital that the instructions within this manual are adhered to at all times. The unit must be installed by qualified personnel.
- The unit can only be repaired by qualified installer centre, personnel or an authorised dealer.
- Maintenance and operation must be carried out according to the recommended time and frequency, as stated in this manual.
- Use genuine standard spare parts only.  
Failure to comply with these recommendations will invalidate the warranty.
- Swimming Pool Heat Pump Unit heats the swimming pool water and keeps the temperature constant.

Our heat pump has following characteristics:

## 1 Durable

The heat exchanger is made of PVC & Titanium tube which can withstand prolonged exposure to swimming pool water.

## 2 Installation flexibility

The unit can be installed outdoors.

## 3 Quiet operation

The unit comprises an efficient rotary/ scroll compressor and a low-noise fan motor, which guarantees its quiet operation.

## 4 Advanced controlling

The unit includes micro-computer controlling, allowing all operation parameters to be set. Operation status can be displayed on the LCD wire controller and Aqua Temp App

## ● WARNING

Do not use means to accelerate the defrosting process or to clean, Other than those recommended by the manufacturer.

The appliance shall be stored in a room without continuously operating ignition sources (for example: open flames, an Operating gas appliance or an operating electric heater.)

Do not pierce or burn.

Be aware that refrigerants may not contain an odour,

Appliance shall be installed, operated and stored in a room with a floor area larger than 30m<sup>2</sup>.

NOTE The manufacturer may provide other suitable examples or may provide additional information about the refrigerant odour.



# 1. PREFACE

---

- This appliance can be used by children aged from 8 years and above and persons with reduced physical, sensory or mental capabilities or lack of experience and knowledge if they have been given supervision or instruction concerning use of the appliance in a safe way and understand the hazards involved. Children shall not play with the appliance. Cleaning and user maintenance shall not be made by children without supervision.
- If the supply cord is damaged, it must be replaced by the manufacturer, its service agent or similarly qualified persons in order to avoid a hazard.
- The appliance shall be installed in accordance with national wiring regulations.
- Do not operate your air conditioner in a wet room such as a bathroom or laundry room.
- Before obtaining access to terminals, all supply circuits must be disconnected.
- An all-pole disconnection device which has at least 3mm clearances in all poles, and have a leakage current that may exceed 10mA, the residual current device (RCD) having a rated residual operating current not exceeding 30mA, and disconnection must be incorporated in the fixed wiring in accordance with the wiring rules.
- Do not use means to accelerate the defrosting process or to clean, other than those recommended by the manufacturer
- The appliance shall be stored in a room without continuously operating ignition sources (for example: open flames, an operating gas appliance or an operating electric heater.)
- Do not pierce or burn
- Appliance shall be installed, operated and stored in a room with a floor area larger than 30 m<sup>2</sup>  
Be aware that refrigerants may not contain an odour.  
The installation of pipe-work shall be kept to a minimum 30 m Max  
Spaces where refrigerant pipes shall be compliance with national gas regulations.  
Servicing shall be performed only as recommended by the manufacturer.  
The appliance shall be stored in a well-ventilated area where the room size corresponds to the room area as specified for operation.  
All working procedure that affects safety means shall only be carried by competent persons.
- Transport of equipment containing flammable refrigerants  
Compliance with the transport regulations  
Marking of equipment using signs  
Compliance with local regulations  
Disposal of equipment using flammable refrigerants  
Compliance with national regulations  
Storage of equipment/appliances  
The storage of equipment should be in accordance with the manufacturer's instructions.  
Storage of packed (unsold) equipment  
Storage package protection should be constructed such that mechanical damage to the equipment inside the package will not cause a leak of the refrigerant charge.  
The maximum number of pieces of equipment permitted to be stored together will be determined by local regulations.

# 1. PREFACE

---

## Caution & Warning

1. The unit can only be repaired by qualified installer centre personnel or an authorised dealer. (for Europe market)
2. This appliance is not intended for use by persons (including children) with reduced physical sensory or mental capabilities, or lack of experience and knowledge, unless they have been given supervision or instruction concerning use of the appliance by a person responsible for their safety. (for Europe market)  
Children should be supervised to ensure that they do not play with the appliance.
3. Please make sure that the unit and power connection have good earthing, otherwise may cause electrical shock.
4. If the supply cord is damaged, it must be replaced by the manufacturer or our service agent or similarly qualified person in order to avoid a hazard.
5. Directive 2002/96/EC (WEEE):  
The symbol depicting a crossed-out waste bin that is underneath the appliance indicates that this product, at the end of its useful life, must be handled separately from domestic waste, must be taken to a recycling centre for electric and electronic devices or handed back to the dealer when purchasing an equivalent appliance.
6. Directive 2002/95/EC (RoHS): This product is compliant with directive 2002/95/EC (RoHS) concerning restrictions for the use of harmful substances in electric and electronic devices.
7. The unit CANNOT be installed near the flammable gas. Once there is any leakage of the gas, fire can occur.
8. Make sure that there is a circuit breaker for the unit, lack of circuit breaker can lead to electrical shock or fire.
9. The heat pump located inside the unit is equipped with an over-load protection system. It does not allow for the unit to start for at least 3 minutes from a previous stoppage.
10. The unit can only be repaired by the qualified personnel of an installer center or an authorized dealer. (for North America market)
11. All electrical connections must be made by a qualified electrician in accordance with all local state Federal government electrical regulations and the latest edition of AS/NZS 3000 wiring rules.
12. USE SUPPLY WIRES SUITABLE FOR 75°C.
13. Caution: Single wall heat exchanger, not suitable for potable water connection.

## 2.SPECIFICATIONS

### 2.1 Performance data of Swimming Pool Heat Pump Unit

\*\*\* REFRIGERANT : R32

UNIT		1H-PASRW030SV113	1H-PASRW040SV118
Heating capacity (27/24℃)	kW	1.95-10.90	5.27-15.66
	Btu/h	6655-37201	17986-53447
Heating Power Input	kW	0.15-1.92	0.46-2.80
COP		12.92-5.67	11.53-5.59
Heating capacity (15/12℃)	kW	1.86-8.40	3.81-11.67
	Btu/h	6348-28668	13003-39829
Heating Power Input	kW	0.30-1.83	0.59-2.71
COP		6.20-4.59	6.48-4.31
Power Supply		220-240V~/50Hz	220-240V~/50Hz
Compressor Quantity		1	1
Compressor		rotary	rotary
Fan Number		1	1
Fan Power Input	W	75	75
Fan Rotate Speed	RPM	400-800	400-750
Fan Direction		horizontal	horizontal
Noise	dB(A)	37-48	41-52
Water Connection	mm	48.3	48.3
Water Flow Volume	m <sup>3</sup> /h	4.6	6.6
Water Pressure Drop(max)	kPa	4.0	5.0
Unit Net Dimensions(L/W/H)	mm	See the drawing of the units	
Unit Ship Dimensions(L/W/H)	mm	See package lable	
Net Weight	kg	61	87
Shipping Weight	kg	see package label	

**NOTE:** Unit must be installed by a Licensed Electrical Contractor in accordance with AS/NZS3000 latest edition and all Local/State/Federal Government regulations and laws. The power feed must be supplied via an RCD with a residual operating current not exceeding 30 mA.

#### Hayward Pool Products (Australia) Pty Ltd.

Heating: Outdoor air temp: 27°C/24°C, Inlet watertemp:26°C  
Outdoor air temp: 15°C/12°C, Inlet watertemp:26°C



Operating range:

Ambient temperature:-7—43°C

Water temperature:9-40°C

## 2.SPECIFICATIONS

### 2.1 Performance data of Swimming Pool Heat Pump Unit

\*\*\* REFRIGERANT : R32

UNIT		1H-PASRW050SV120	1H-PASRW060SV124
Heating capacity (27/24°C)	kW	5.61-18.17	9.37-23.88
	Btu/h	19141-61996	31970-81540
Heating Power Input	kW	0.43-3.17	0.76-3.85
COP		13.05-5.73	12.34-6.20
Heating capacity (15/12°C)	kW	2.33-12.78	6.81-17.73
	Btu/h	7950-43605	23230-60400
Heating Power Input	kW	0.43-3.11	1.01-3.74
COP		5.42-4.11	6.74-4.74
Power Supply		220-240V~/50Hz	220-240V~/50Hz
Compressor Quantity		1	1
Compressor		rotary	rotary
Fan Number		1	1
Fan Power Input	W	75	150
Fan Rotate Speed	RPM	500-750	500-800
Fan Direction		horizontal	horizontal
Noise	dB(A)	42-53	45-52
Water Connection	mm	48.3	48.3
Water Flow Volume	m <sup>3</sup> /h	7.3	10.3
Water Pressure Drop(max)	kPa	6	7
Unit Net Dimensions(L/W/H)	mm	See the drawing of the units	
Unit Ship Dimensions(L/W/H)	mm	See package label	
Net Weight	kg	99	112
Shipping Weight	kg	See package label	

**NOTE:** Unit must be installed by a Licensed Electrical Contractor in accordance with AS/NZS3000 latest edition and all Local/State/Federal Government regulations and laws. The power feed must be supplied via an RCD with a residual operating current not exceeding 30 mA.

#### Hayward Pool Products (Australia) Pty Ltd.

Heating: Outdoor air temp: 27°C/24.3°C, Inlet water temp:26°C

Outdoor air temp: 15°C/12°C, Inlet water temp:26°C

Operating range:

Ambient temperature:-10-43°C

Water temperature:9-40°C



## 2.SPECIFICATIONS

### 2.1 Performance data of Swimming Pool Heat Pump Unit

\*\*\* REFRIGERANT : R32

UNIT		1H-PASRW060SV125	1H-PASRW070SV128
Heating capacity (27/24°C)	kW	10.46-24.96	10.46-27.92
	Btu/h	35689-85164	35689-95263
Heating Power Input	kW	0.81-3.51	0.81-4.41
COP		12.86-7.11	12.86-6.34
Heating capacity (15/12°C)	kW	7.17-17.79	7.17-21.55
	Btu/h	24464-60699	24464-73529
Heating Power Input	kW	0.98-3.64	0.98-4.74
COP		7.32-4.89	7.32-4.55
Power Supply		380-415V/3N~50Hz	380-415V/3N~50Hz
Compressor Quantity		1	1
Compressor		rotary	rotary
Fan Number		1	1
Fan Power Input	W	150	150
Fan Rotate Speed	RPM	500-800	500-850
Fan Direction		horizontal	horizontal
Noise	dB(A)	43-52.5	43-53.5
Water Connection	mm	48.3	48.3
Water Flow Volume	m <sup>3</sup> /h	10.7	12.5
Water Pressure Drop(max)	kPa	7	8
Unit Net Dimensions(L/W/H)	mm	See the drawing of the units	
Unit Ship Dimensions(L/W/H)	mm	See package lable	
Net Weight	kg	120	120
Shipping Weight	kg	See package label	

**NOTE:** Unit must be installed by a Licensed Electrical Contractor in accordance with AS/NZS3000 latest edition and all Local/State/Federal Government regulations and laws. The power feed must be supplied via an RCD with a residual operating current not exceeding 30 mA.

#### Hayward Pool Products (Australia) Pty Ltd.

Heating: Outdoor air temp: 27°C/24.3°C, Inlet water temp:26°C

Outdoor air temp: 15°C/12°C, Inlet water temp:26°C

Operating range:

Ambient temperature:-10-43°C

Water temperature:9-40°C



## 2.SPECIFICATIONS

### 2.2 The dimensions for Swimming Pool Heat Pump Unit

Model: 1H-PASRW030SV113

unit: mm

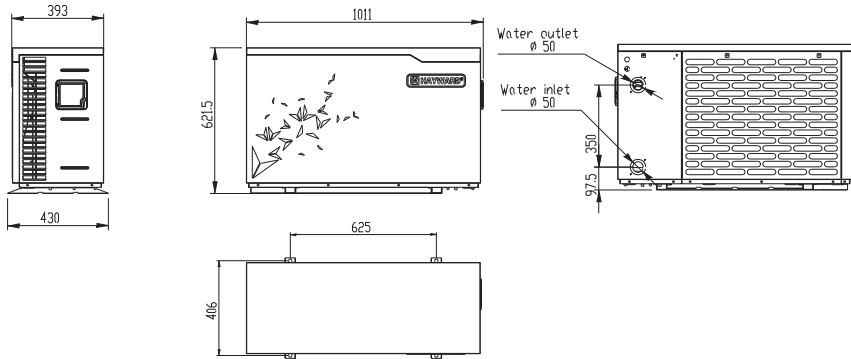

Model: 1H-PASRW040SV118

unit: mm

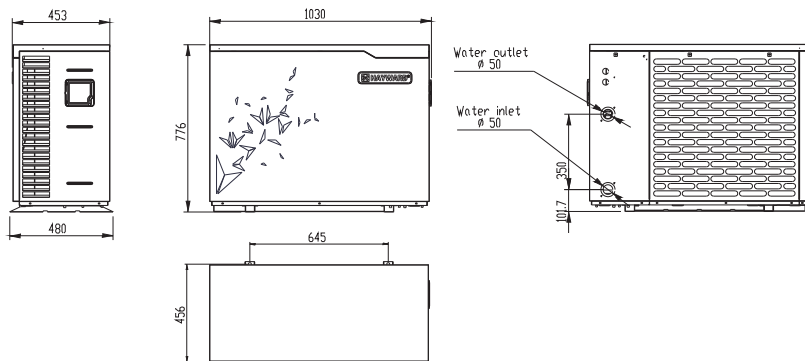

## 2.SPECIFICATIONS

### 2.2 The dimensions for Swimming Pool Heat Pump Unit

Model: 1H-PASRW050SV120/1H-PASRW060SV124  
1H-PASRW060SV125/1H-PASRW070SV128

unit: mm

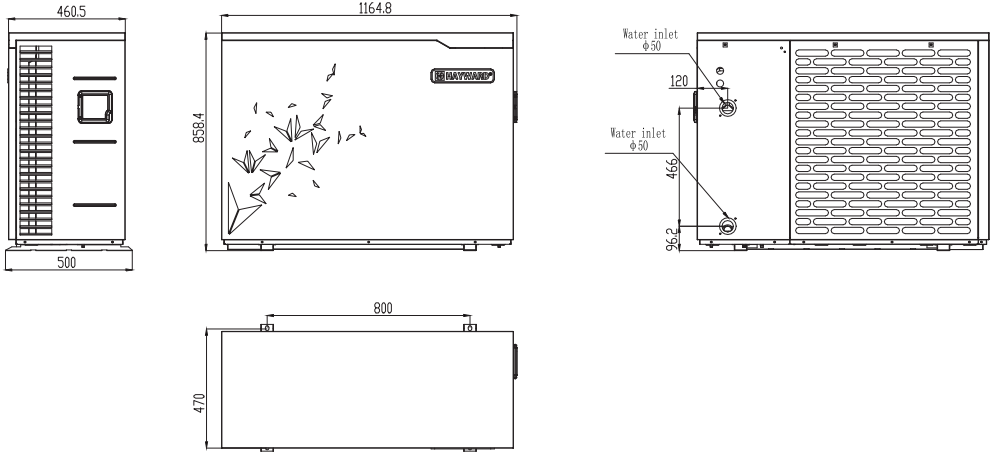

# 3.INSTALLATION AND CONNECTION

## 3.1 Installation illustration

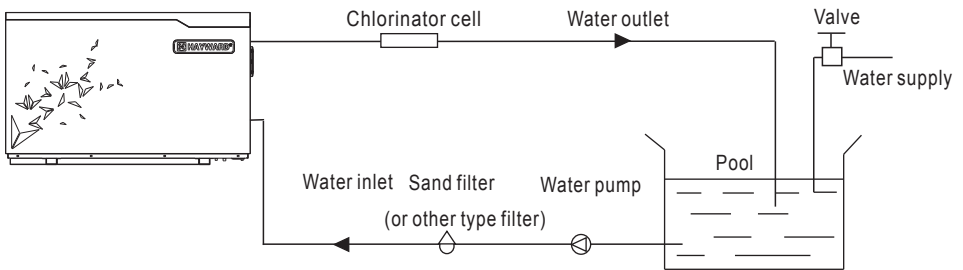

### Installation items:

The factory only provides the main unit and unions for the water connection; the other items in the illustration are necessary spare parts for the water system, that provided by users or the installer.

### Attention:

Please follow these steps when using for the first time

1. Open valve and charge water.
2. Make sure that the pump and the water-in pipe have been filled with water.
3. Close the valve and start the unit.

ATTN: It is necessary that the water-in pipe is higher than the pool surface.

# 3. INSTALLATION AND CONNECTION

## 3.2 Swimming Pool Heat Pumps Location

The unit will perform well in any outdoor location provided that the following three factors are presented:

1. Fresh Air -
2. Electricity -
3. Pool filter piping

The unit may be installed virtually anywhere outdoors. For indoor pools please consult the supplier. Unlike a gas heater, it has no draft or pilot light problem in a windy area.

DO NOT place the unit in an enclosed area with a limited air volume, where the units discharge air will be re-circulated.

DO NOT place the unit to shrubs which can block air inlet. These locations deny the unit of a continuous source of fresh air which reduces its efficiency and may prevent adequate heat delivery.

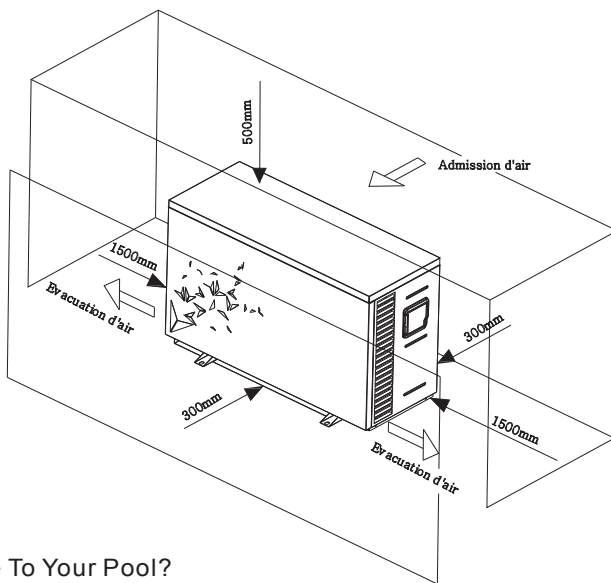

## 3.3 How Close To Your Pool?

Normally, the pool heat pump is installed within 7.5 metres of the pool. The longer the distance from the pool, the greater the heat loss from the piping. For the most part, the piping is buried. Therefore, the heat loss is minimal for runs of up to 15 meters (15 meters to and from the pump = 30 meters total), unless the ground is wet or the water table is high. A very rough estimate of heat loss per 30 meters is 0.6 kW-hour, (2000 BTU) for every 5 °C difference in temperature between the pool water and the ground surrounding the pipe, which translates to about 3% to 5% increase in run time.

# 3. INSTALLATION AND CONNECTION

## 3.4 Swimming Pool Heat Pumps Plumbing

The Swimming Pool Heat Pumps exclusive rated flow titanium heat exchanger requires no special plumbing arrangements except bypass (please set the flow rate according to the nameplate). The water pressure drop is less than 10kPa at max. Flow rate. Since there is no residual heat or flame Temperatures, The unit does not need copper heat sink piping. PVC pipe can be run straight into the unit.

Location: Connect the unit in the pool pump discharge (return) line downstream of all filter and pool pumps, and upstream of any chlorinators, ozonators or chemical pumps.

Standard model have slip glue fittings which accept 32mm or 50 mm PVC pipe for connection to the pool or spa filtration piping. By using a 50NB to 40NB you can plumb 40NB

Give serious consideration to adding a quick coupler fitting at the unit inlet and outlet to allow easy draining of unit for winterizing and to provide easier access should servicing be required.

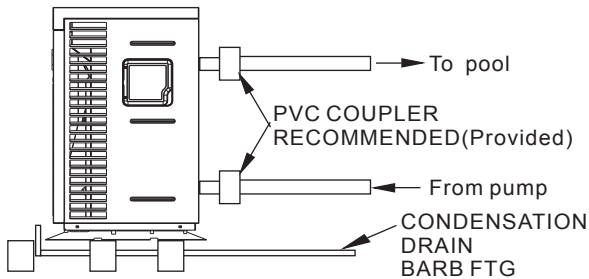

Condensation: Since the Heat pump cools down the air about 4 -5°C, water may condense on the fins of the horseshoe shaped evaporator. If the relative humidity is very high, this could be as much as several litres an hour. The water will run down the fins into the basepan and drain out through the barbed plastic condensation drain fitting on the side of the basepan. This fitting is designed to accept 20mm clear vinyl tubing which can be pushed on by hand and run to a suitable drain. It is easy to mistake the condensation for a water leak inside the unit.

NB: A quick way to verify that the water is condensation is to shut off the unit and keep the pool pump running. If the water stops running out of the basepan, it is condensation. AN EVEN QUICKER WAY IS to TEST THE DRAIN WATER FOR CHLORINE - if there is no chlorine present, then it's condensation.

# 3. INSTALLATION AND CONNECTION

## 3.5 Swimming Pool Heat Pumps Electrical Wiring

NOTE: Although the unit heat exchanger is electrically isolated from the rest of the unit, it simply prevents the flow of electricity to or from the pool water. Grounding the unit is still required to protect you against short circuits inside the unit. Bonding is also required.

The unit has a separate molded-in junction box with a standard electrical conduit nipple already in place. Just remove the screws and the front panel, feed your supply lines in through the conduit nipple and wire-nut the electric supply wires to the three connections already in the junction box (four connections if three phase). To complete electrical hookup, connect Heat Pump by electrical conduit, UF cable or other suitable means as specified (as permitted by local electrical authorities) to a dedicated AC power supply branch circuit equipped with the proper circuit breaker, disconnect or time delay fuse protection.

Disconnect - A disconnect means (circuit breaker, fused or un-fused switch) should be located within sight of and readily accessible from the unit. This is common practice on commercial and residential air conditioners and heat pumps. It prevents remotely-energizing unattended equipment and permits turning off power at the unit while the unit is being serviced.

### Top cover removal instruction

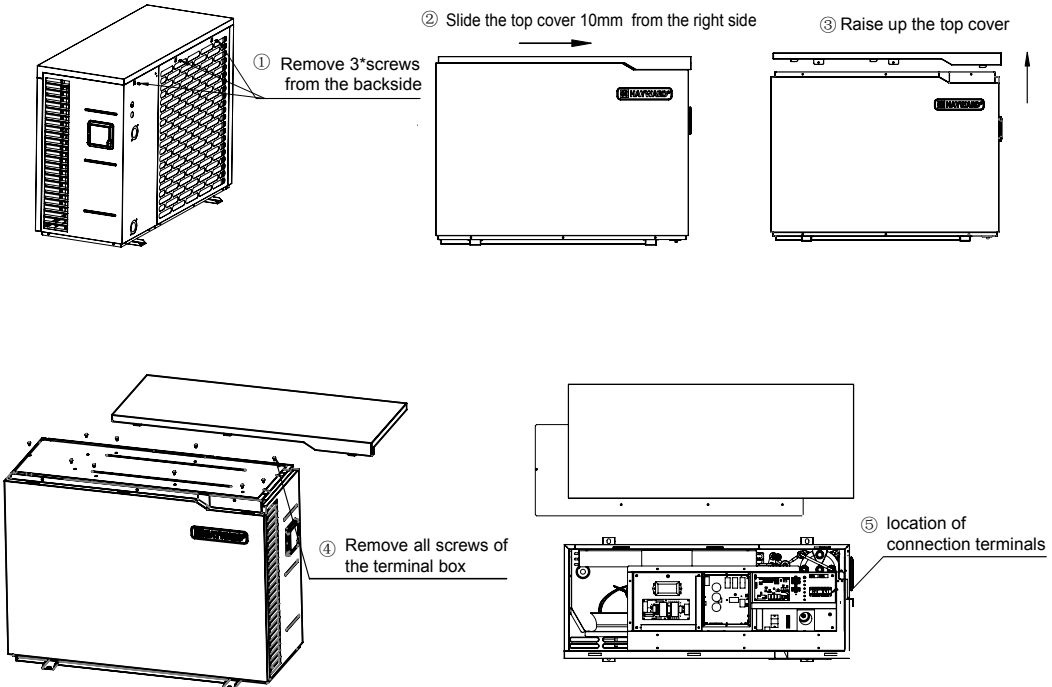

## 3. INSTALLATION AND CONNECTION

---

### 3.6 Initial start-up of the Unit

NOTE- In order for the unit to heat the pool or spa, the filter pump must be running to circulate water through the heat exchanger.

Start up Procedure- After installation is completed, you should follow these steps:

1. Turn on your filter pump. Check for water leaks and verify flow to and from the pool.
2. Turn on the electrical power supply to the unit, then press the key ON/OFF of wire controller, It should start in several seconds.
3. After running a few minutes make sure the air leaving the top(side) of the unit is cooler (Between 5-10 °C)
4. With the unit operating turn the filter pump off. The unit should also turn off automatically,
5. Allow the unit and pool pump to run 24 hours per day until desired pool water temperature is reached. When the water-in temperature reaches this setting, the unit will slow down for a period of time, if the temperature is maintained for 45 minutes the unit will turn off. The unit will now automatically restart (as long as your pool pump is running) when the pool temperature drops more than 0.2 below set temperature.

Time Delay- The unit is equipped with a 3 minute built-in solid state restart delay included to protect control circuit components and to eliminate restart cycling and contactor chatter. This time delay will automatically restart the unit approximately 3 minutes after each control circuit interruption. Even a brief power interruption will activate the solid state 3 minute restart delay and prevent the unit from starting until the 5 minute countdown is completed.



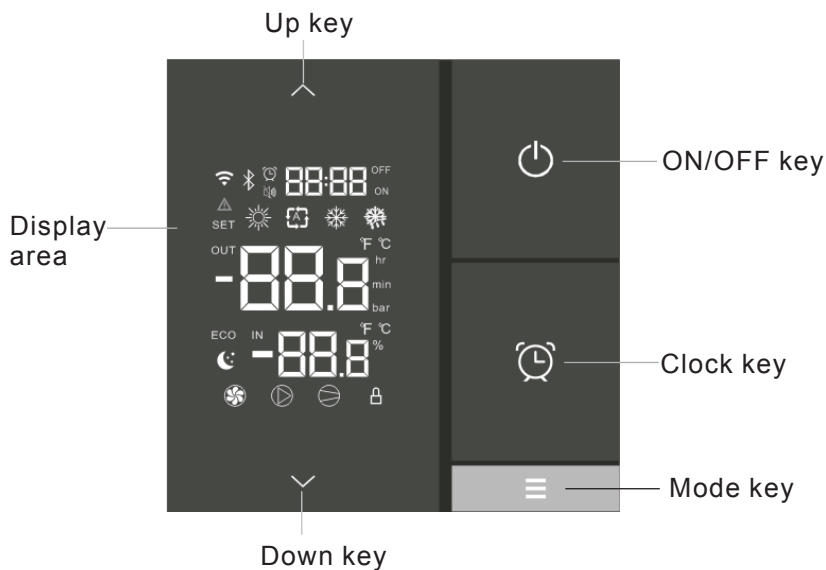

## 4. Use and Operation Instruction

### 1. Interface display

























### 2. Key and icon function instruction

#### 2.1 Key function instruction

Key symbols	Designation	Function
	On-off key	It is used to carry out startup & shutdown, cancel current operation, and return to the last level of operation.
	Clock key	It is used as user clock, and to carry out timing setting.
	Mode key	It is used to switch the unit mode, temperature setting, and parameter setting.
	Up key	It is used to page up, and increase variable value.
	Down key	It is used to page down, and decrease variable value.

# 4. Use and Operation Instruction

## 2.2. Icon function instruction

Icon symbol	Designation	Function
	Cooling symbol	It will display during cooling (there is no limit to startup & shutdown, and it is optional when the unit is cooling-only unit or heating-and-cooling unit).
	Heating symbol	It will display during heating (there is no limit to startup & shutdown, and it is optional when the unit is heating-only unit or heating-and-cooling unit)(Flashing while on defrosting).
	Automatic symbol	It will display under the automatic mode (there is no limit to startup & shutdown, and it is optional when the unit is heating-and-cooling unit).
	Defrosting symbol	It will display in the defrosting process of the unit.
	Compressor symbol	It will display when compressor is started.
	Water pump symbol	It will display when water pump is started.
	Fan symbol	It will display when fan is started.
	Mute symbol	When the timing mute function is started, it keeps bright for a long time. When it is in mute state, it will flash. Or else, it is off.
	Timing symbol	It will display after the user sets the timing, and multiple timing intervals can be set.
	Timer On/Off symbol	It will display after the user sets the timer on/ off settings, and the function is started.
	Water outlet symbol	When the auxiliary display area displays the water outlet temperature, the light is on.
	Water inlet symbol	When the main display area displays the water inlet temperature, the light is on.
	Locking key symbol	When the keyboard is locked, it is on.
	Fault symbol	In case of unit fault, it is on.
	Wireless signal symbol	When the unit is connected to WIFI module, it will display according to the strength of WIFI signal.
	Bluetooth symbol	When the unit is connected to Bluetooth® module, it is on.
	Degrees Celsius symbol	When main display area or auxiliary display area displays degrees Celsius, it is on.
	Degrees Fahrenheit symbol	When main display area or auxiliary display area displays degrees Fahrenheit, it is on.
	Setting symbol	When the parameter is adjustable, it is on.
	Minute symbol	When main display area displays minute digit, it is on.
	Hour symbol	When main display area displays hour digit, it is on.
	Pressure symbol	When main display area displays pressure value, it is on.

# 4. Use and Operation Instruction

## 2.3. Startup & shutdown

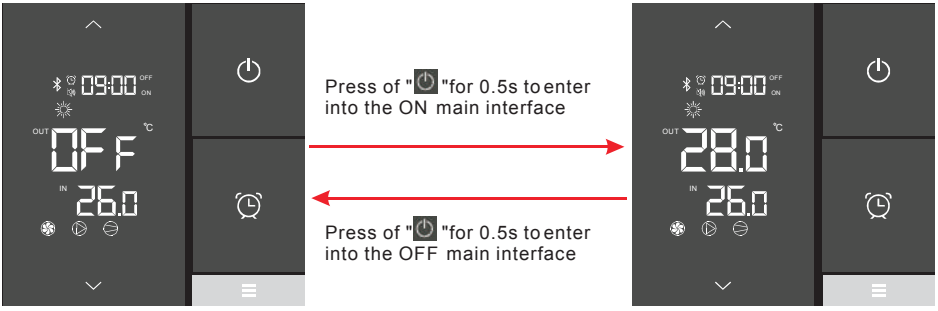

### Notes:

- (1) Startup & shutdown operation can only be conducted in the main interface.
- (2) When there is no operation for 1 minute, it will display with full screen off, click any key for returning to ON/OFF main interface.

When the unit is started under the control of wire controller, if using the emergency switch to shut down, the wire controller will display as follows:  
Operations are the same as under ON/OFF main interface.

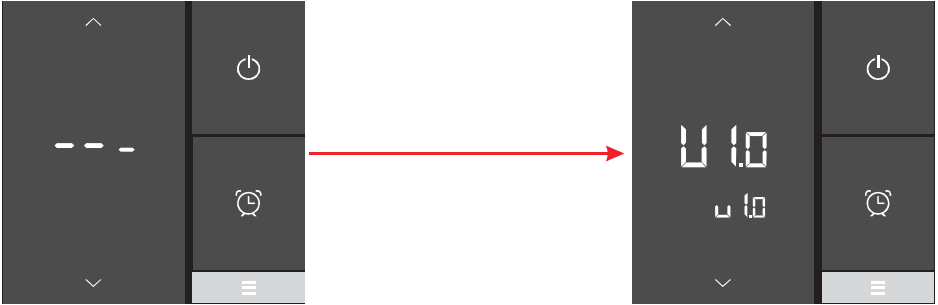

## 2.4. Mode switch

Under the main interface, Short press "☰" to switch the unit among heating "☀️", automatic "🏠" and cooling "❄️" mode.

# 4. Use and Operation Instruction

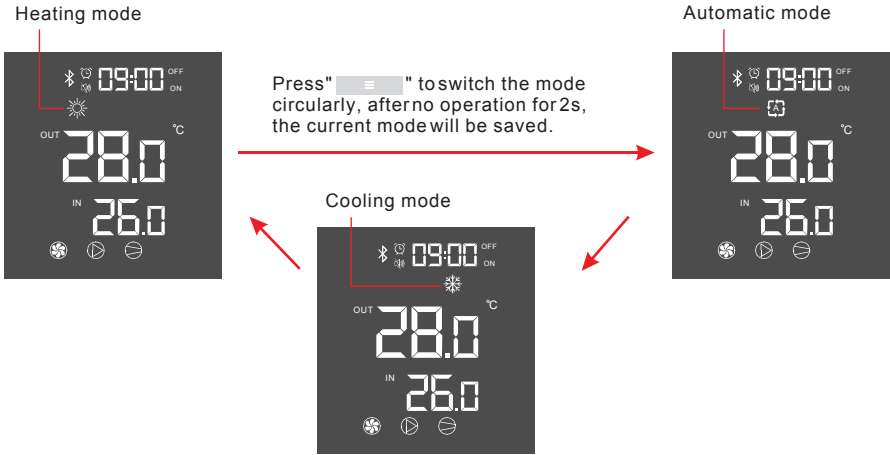

### Operation descriptions:

- 1) Mode switch operation can only be conducted in the main interface.
- 2) When the unit is under the defrosting state, the defrosting symbol "❄" is flashing.
- 3) After completing the defrosting, the unit will be automatically switched to the heating/automatic mode (keeping consistent with the mode before defrosting).

## 2.5. Temperature setting

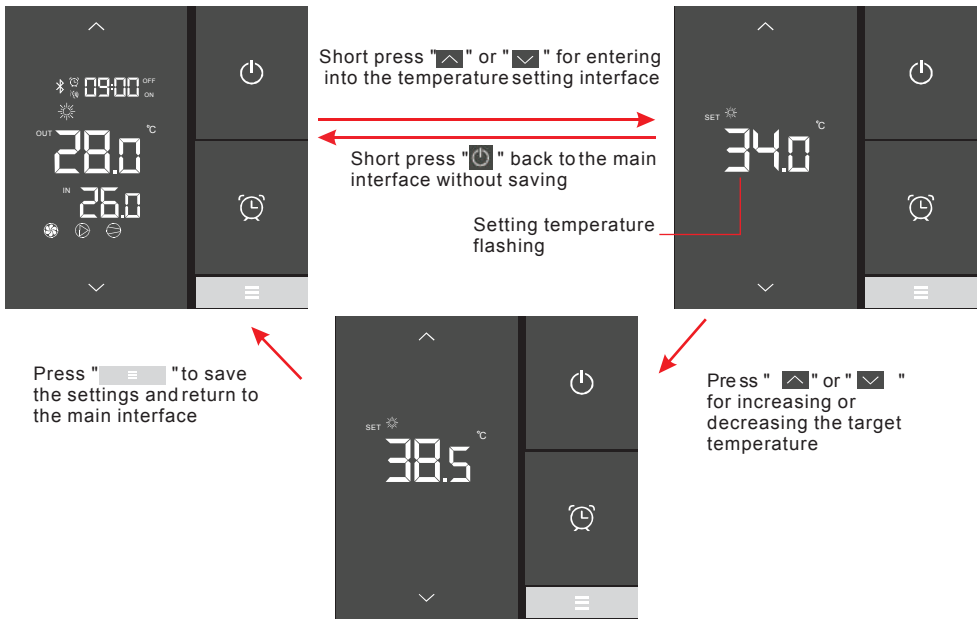

Notes: If there is no operation for 5 s, the system will automatically memorize the settings, and return to the main interface.

## 4. Use and Operation Instruction

Remark:

The wire controller can display the temperature unit as "°F" or "°C" according to the unit model you bought.

### 2.6. Clock setting

#### 2.6.1 System time setting

- 1) .Permanent awakening clock key

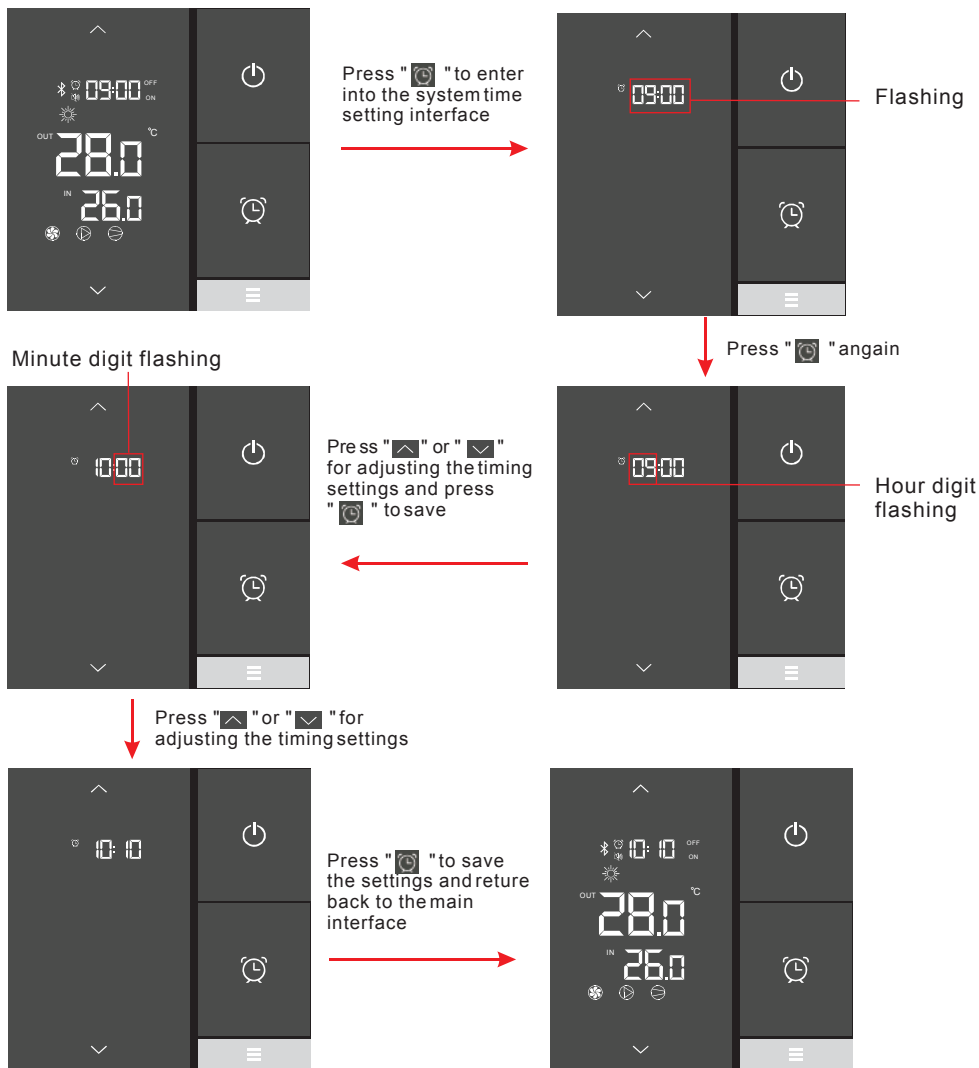

Notes: Under the clock setting interface, if short press "🕒", the change will not be saved and return to the main interface; if there is no operation for 5s, the system will automatically memorize the settings, and return back to the main interface.



# 4. Use and Operation Instruction

## 2.6.4 Mute setting

Following the 2.6.2 steps to select Mute function, "🔊" is flashing, then press "🕒" to confirm and enter into Mute setting interface. Mute ON/OFF setting operation refers to 6.2.1.

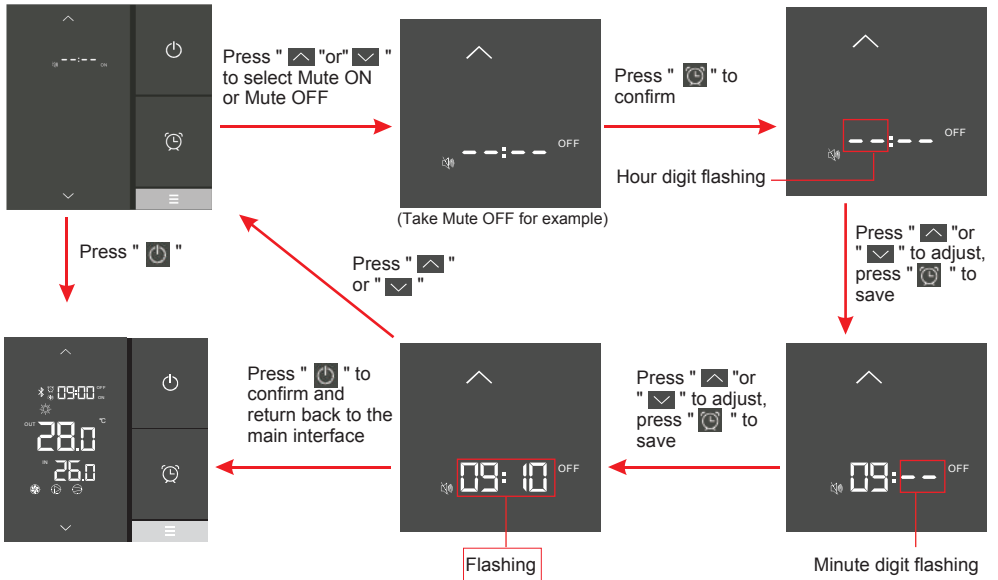

### Notes:

- 1) Mute ON operation refers to the setting of Mute OFF.
- 2) While the hour or minute digit is flashing, press "🔇" to delete mute on or mute off setting, it shows "--:--", then press "🔇" to save and return to the main interface, the mute icon not display;
- 3) If there is no operation for 20 s, the system will automatically memorize settings ,and return to the main interface.

## 4. Use and Operation Instruction

### 2.7. Keyboard lock

To avoid others' misoperation, please lock the wire controller after completing the settings.

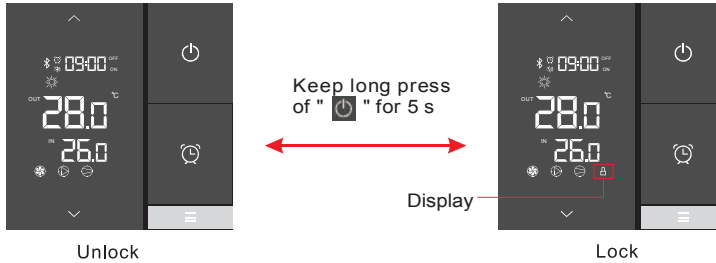

Notes:

- 1). Under the locked screen interface, only unlocking operation is available, and the screen will be lightened after other operations conducted.
- 2). Under the OFF interface, locking operation is available, and the operation method is the same as locking screen under the ON interface.

### 2.8. Fault interface

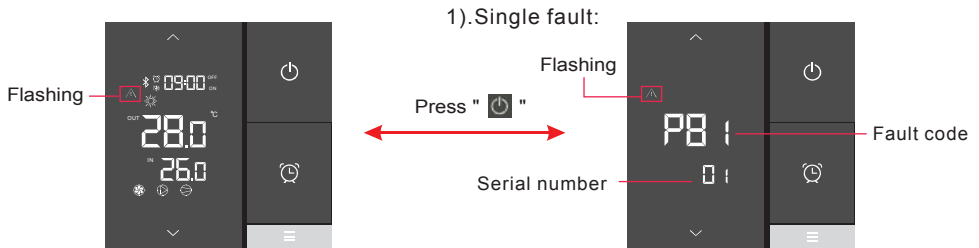

2). Two or more faults:

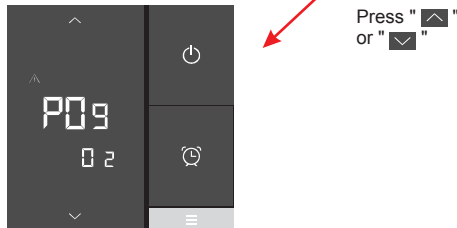

# 4. Use and Operation Instruction

## 2.9. Electrical Diagrams

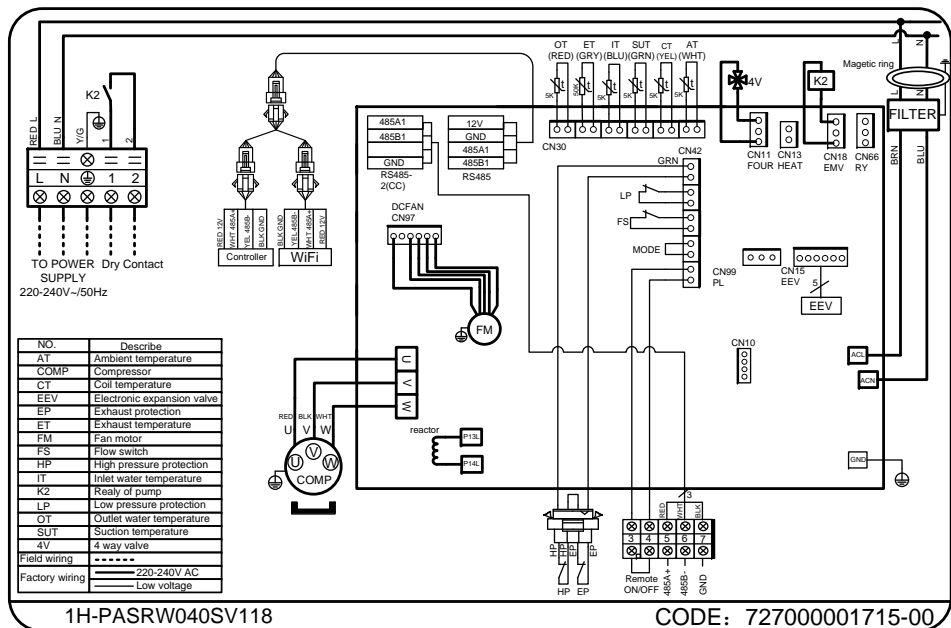
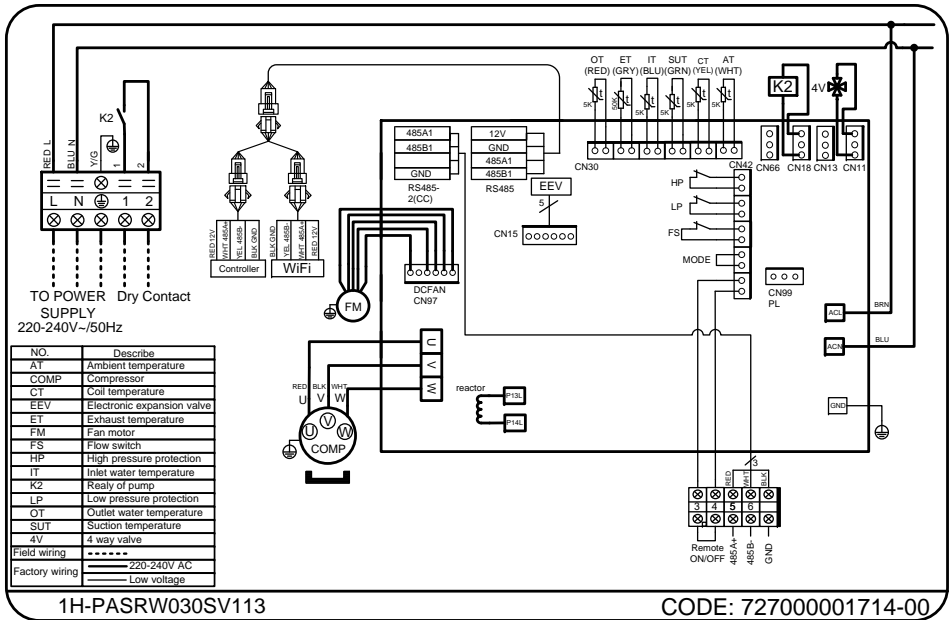

# 4. Use and Operation Instruction

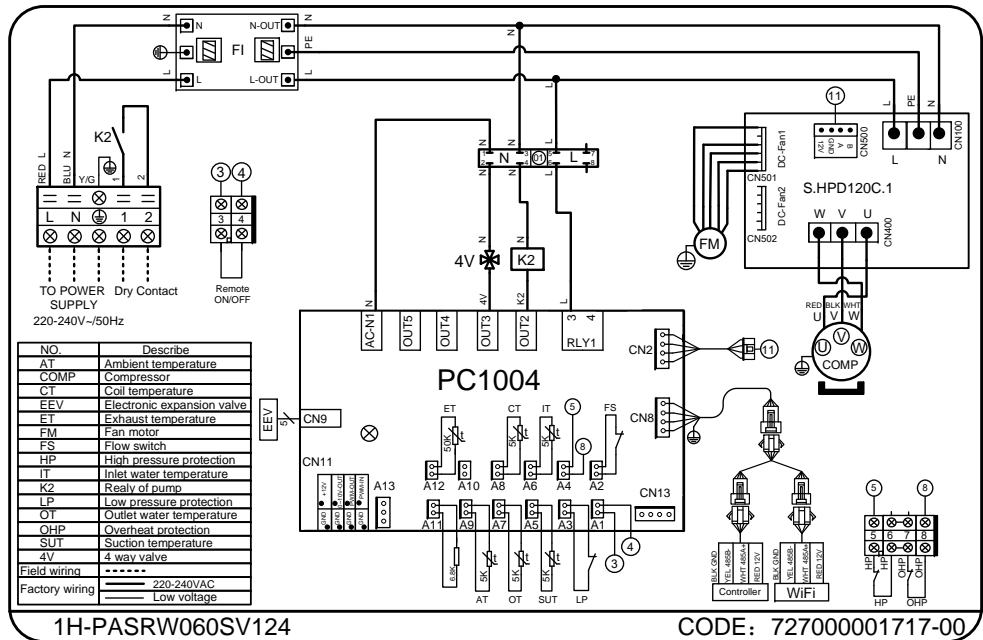
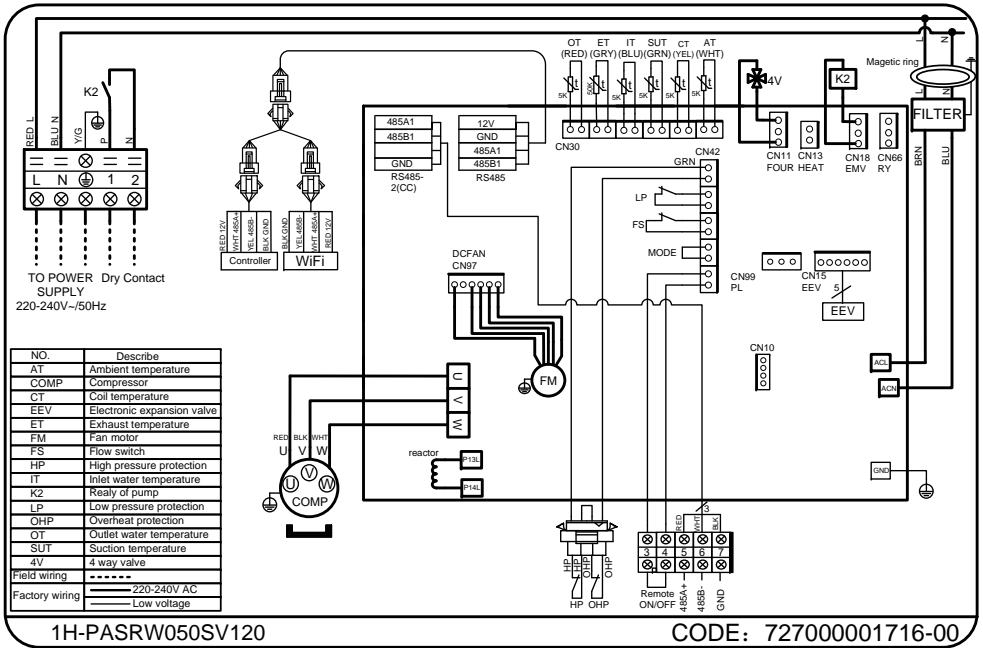

# 4. Use and Operation Instruction

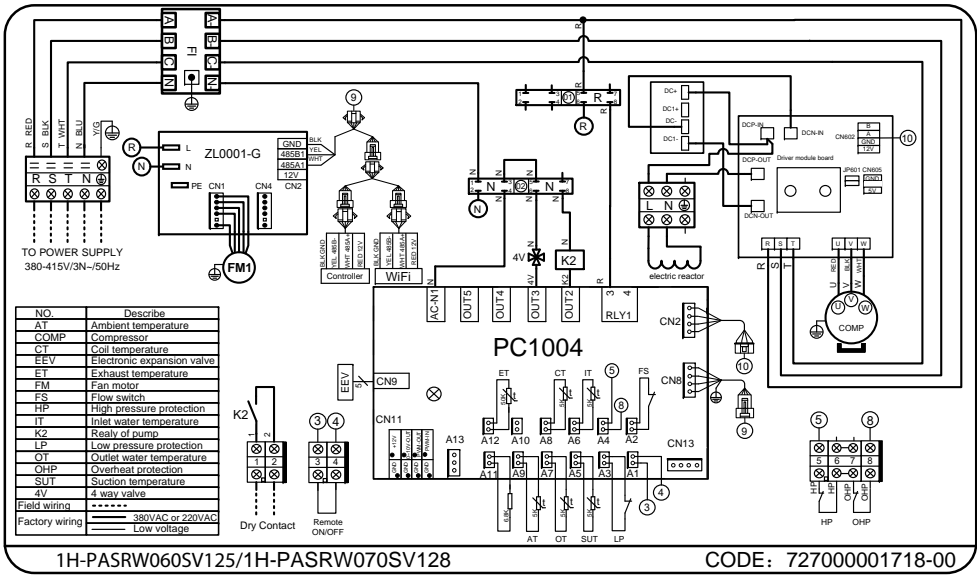

## 4. Use and Operation Instruction

### 3. Parameter list and breakdown table

#### 3.1 Electronic control fault table

Can be judged according to the remote controller failure code and troubleshooting

Protect/fault	Fault display	Reason	Elimination methods
Inlet Temp. Sensor Fault	P01	The temp. sensor is broken or short circuit	Check or change the temp. sensor
Outlet Temp. Sensor Fault	P02	The temp. sensor is broken or short circuit	Check or change the temp. sensor
Ambient Temp. Sensor Fault	P04	The temp. sensor is broken or short circuit	Check or change the temp. sensor
Coil 1 Temp. Sensor Fault	P05	The temp. sensor is broken or short circuit	Check or change the temp. sensor
Coil 2 Temp. Sensor Fault	P15	The temp. sensor is broken or short circuit	Check or change the temp. sensor
Suction Temp. Sensor Fault	P07	The temp. sensor is broken or short circuit	Check or change the temp. sensor
Exhaust Temp. Sensor Fault	P081	The temp. sensor is broken or short circuit	Check or change the temp. sensor
Exhaust Air Over-Temp Prot.	P082	The compressor is overload	Check whether the compressor running normally
Antifreeze Temp. Sensor Fault	P09	The temp. sensor is broken or short circuit	Check or change the temp. sensor
Pressure Sensor Fault	PP	The pressure sensor is broken	Check or change the pressure sensor or pressure
High Pressure Prot.	E01	The high-pressure switch is broken	Check the pressure switch and cold circuit
Low Pressure Prot.	E02	The low-pressure switch is broken	Check the pressure switch and cold circuit
Flow Switch Prot.	E03	The temp. sensor is broken or short circuit	Check or change the temp. sensor
Waterway Anti-freezing Prot.	E05	No water/little water in water system	Check the pipe waterflow and water pump
Excess Water In/Out Temp. Diff. Prot.	E06	Water flow is not enough and low differential pressure	Check the pipe water flow and whether water system is jammed or not
Anti-freezing Prot.	E07	Water flow is not enough	Check the pipe water flow and whether water system is jammed or not
Primary Anti-freezing Prot.	E19	The ambient temp. is low	Check whether the ambient temp. is low or not
Secondary Anti-freezing Prot.	E29	The ambient temp. is low	Check whether the ambient temp. is low or not
Comp. Overcurrent Prot.	E051	The compressor is overload	Check whether the system of the compressor running normally
Communication Fault	E08	Communication failure between wire controller and mainboard	Check the wire connection between remote wire controller and mainboard
Comm. Fault(Mainboard-DC Fan)	E081	Speed control module and main board communication fail	Check the communication connection
Low AT Prot.	TP	The ambient temp. is low	Check whether the ambient temp. is low or not
EC fan feedback Fault	F051	There is something wrong with fan motor and fan motor stops running	Check whether fan motor is broken or locked or not
Fan Motor1 Fault	F031	1. Motor is in locked-rotor state 2. The wire connection between DC-fan motor module and fan motor is in bad contact	1. Change a new fan motor 2. Check the wire connection and make sure they are in good contact

## 4. Use and Operation Instruction

Fan Motor 2 Fault	F032	1. Motor is inlocked-rotor state 2. The wire connection between DC-fan motor module and fan motor is in bad contact	1. Change a new fan motor 2. Check the wire connection and make sure they are in good contact
-------------------	------	--	--

### Frequency conversion board fault table:

Protect/fault	Fault display	Reason	Elimination methods
Driver MOP Alarm	F01	MOP drive alarm	Recovery after the 150s
Inverter Board Offline	F02	Frequency conversion board and main board communication failure	Check the communication connection
IPM protection	F03	IPM modular protection	Recovery after the 150s
Comp. Driver Failure	F04	Lack of phase, step or drive hardware damage	Check the measuring voltage check frequency conversion board hardware
DC Fan Fault	F05	Motor current feedback open circuit or short circuit	Check the input voltage measurement
IPM Input Overcurrent Prot.	F06	IPM input current is too large	Check and adjust the current measurement
Inv. DC Over-volt.	F07	DC bus voltage > Dc bus Overload-voltage protection value	Check the input voltage measurement
Inv. DC Under-volt.	F08	DC bus voltage < Dc bus Underload-voltage protection value	Check the input voltage measurement
Inv. Input Under-volt.	F09	The input voltage is low, causing the input current is low	Check the input voltage measurement
Inv. Input Over-volt.	F10	The input voltage is too high, more than outage protection current RMS	Check the input voltage measurement
Inv. Sampling Volt. Fault	F11	The input voltage sampling fault	Check and adjust the current measurement
Comm. Err DSP-PFC	F12	DSP and PFC connect fault	Check the communication connection
Input Over Cur.	F26	The equipment load is too large	Check the input current of the unit whether is bigger than the rate current
PFC fault	F27	The PFC circuit protection	Check the PFC switch tube short circuit or not
IPM Superheat Prot.	F15	The IPM module is overheat	Check and adjust the current measurement
Weak Magnetic Warn	F16	Compressor magnetic force is not enough	Restart the unit after multiple power failures, if the fault still exists, replace the compressor
Inv. Input Out of Phase	F17	The input voltage lost phase	Check and measure the voltage adjustment
IPM Sampling Current Fault	F18	IPM sampling electricity is fault	Check and adjust the current measurement
Inv. Temp. Probe Fault	F19	Sensor is short circuit or open circuit	Inspect and replace the sensor
Inverter Superheat Prot.	F20	The transducer is overheat	Check and adjust the current measurement
Inverter Superheat Warn	F22	Transducer temperature is too high	Check and adjust the current measurement
Comp. Over Cur. Warn	F23	Compressor is too large	Check and adjust the current measurement
Input Over Cur. Warn	F24	Input current is too large	Check and adjust the current measurement
EEPROM Error Warn	F25	MCU error	Check whether the chip is damaged Replace the chip
V15V Over/Under-Volt. Prot	F28	The V15V is overload or undervoltage	Check the V15V input voltage in range 13.5v~16.5v or not

# 4. Use and Operation Instruction

## 3.2 Parameter list

Meaning	Default	Remarks
Refrigeration target temperature set point	27°C	Adjustable
Heating the target temperature set point	27°C	Adjustable
Automatic target temperature set point	27°C	Adjustable

## 4. Interface drawing

### 4.1 Wire control interface diagram and definition

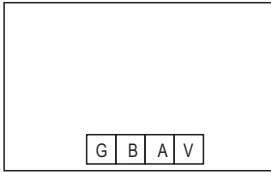

Sign	Meaning
V	12V(power+)
A	485A
B	485B
G	GND(power-)

### 4.2 Controller interface diagram and definition

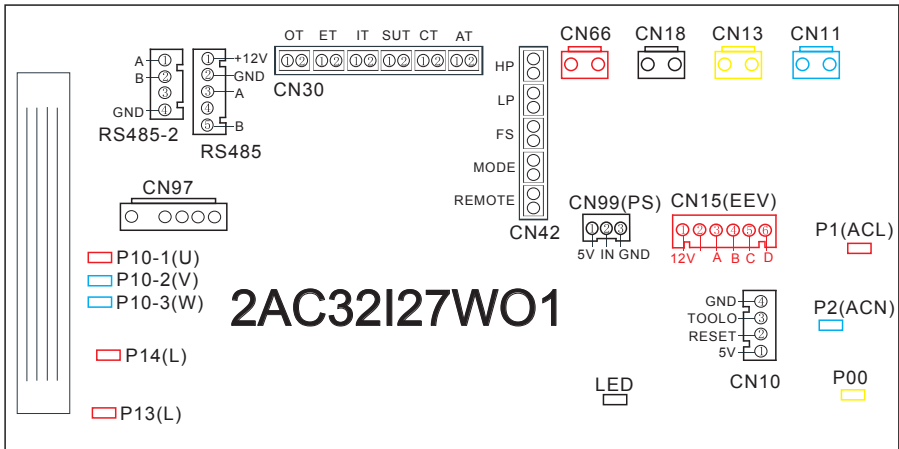

# 4. Use and Operation Instruction

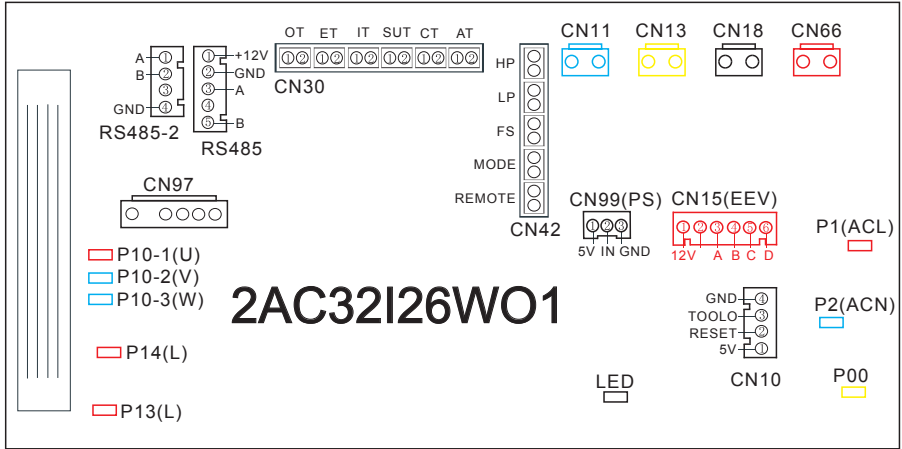

## 4. Use and Operation Instruction

---

Main board of the input and output interface instructions below

Number	Sign	Meaning
01	P10-1/2/3(U/V/W)	Compressor
02	P13(L)/P14(L)	Resistance
03	CN97	DC motor
04	RS485-2	The port for centralized control
05	RS485	Color line controller communication/Wifi
06	OT	Water output temperature
07	ET	System exhaust temperature
08	IT	Water input temperature
09	SUT	System suction temperature
10	CT	System fan coil temperature
11	AT	Ambient temperature
12	HP	System high pressure
13	LP	System low pressure
14	FS	Water flow switch
15	MODE	Mode switch
16	REMOTE	Emergency switch
17	CN11	4-way valve
18	CN13	Reserved
19	CN18	Water pump
20	CN66	Compressor signal
21	CN99	Low pressure sensor
22	CN15	Electronic expansion valve
23	CN10	Program port
24	P00	Grounding
25	P1	Live wire
26	P2	Neutral wire

# 4. Use and Operation Instruction

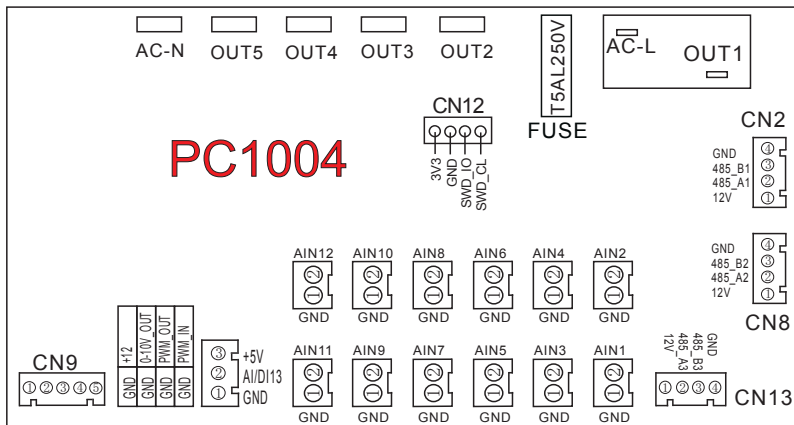

## 4. Use and Operation Instruction

Main board of the input and output interface instructions below

Number	Sign	Meaning
01	OUT1	Compressor ( output 220-230VAC )
02	OUT2	Water pump ( output 220-230VAC )
03	OUT3	4-way valve ( output 220-230VAC )
04	OUT4	High speed of fan/Chassis heating belt
05	OUT5	Low speed of fan (output 220-230VAC )
06	AC-L	Live wire ( input 220-230VAC )
07	AC-N	Neutral wire ( input 220-230VAC )
08	AI/DI01	Emergency switch ( input )
09	AI/DI02	Water flow switch ( input )
10	AI/DI03	System low pressure ( input )
11	AI/DI04	System high pressure ( input )
12	AI/DI05	System suction temperature ( input )
13	AI/DI06	Water input temperature ( input )
14	AI/DI07	Water output temperature ( input )
15	AI/DI08	System 1 coil temperature (input)
16	AI/DI09	Ambient temperature ( input )
17	AI/DI10	Mode switch/System 2 coil temperature (input)
18	AI/DI11	Master-slave machine switch / Antifreeze temperature ( input )
19	AI/DI12	System exhaust temperature ( input )
20	AI/DI13	Compressor current detection/Pressure sensor(input)
21	PWM_IN	Master-slave machine switch / Feedback signal of EC fan ( input )
22	PWM_OUT	AC fan control ( output )
23	0_10V_OUT	EC fan control ( output )
24	+5V	+5V ( output )
25	+12V	+12V ( output )
26	CN2	Frequency conversion board communications
27	CN8	5 inch color display Wifi module Dc fan module
28	CN9	Electronic expansion valve
29	CN12	Program port
30	CN13	The port for centralized control

## 5. Use and Operation Instruction of WIFI module

---

### User Privacy Instructions

---

We take your privacy very seriously and we promise to inform you how we use the data. Users' private data, such as mailboxes, address, before uploading to the cloud, we will get your permission, and we will work hard to protect your data security.

### Description

---

- Receive data signal from cloud server and transmit to the main device;
- Receive data signal from main device and transmit to cloud server;
- To achieve remote upgrade the WIFI module baseplate MCU by cloud server;
- To achieve the remote upgrade of the main device by WIFI module baseplate MCU.

### Technical Parameters

---

**OPERATING VOLTAGE:** DC8V~12V (Recommended value 12V)

**OPERATING CURRENT:** Max. recurrent peak 1A, average standby current 50mA

**TEMP. RANGE:** Operating Temp.: -30℃~+70℃; Storage Temp.: -40℃~+85℃

**LED INDICATOR LIGHT:**

4 lights, Network configuration indicator, router connection indicator, cloud server connection indicator, 485 communication indicator;

**DIMENSION(L×W×H):** 78mm×63mm×24mm

### Installation

- There is a magnet on the back of the WIFI module, it can be installed indoors or outdoors, and avoid direct sunlight;
- Please scan the following QR code to download APP;



# 5. Use and Operation Instruction of WIFI module

## Functional Description

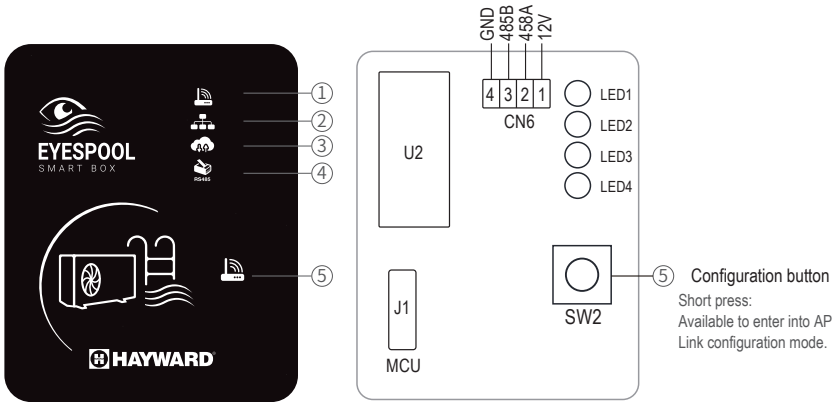

ITEM	NAME	LONG LIGHT	SLOW FLASH	EXTINGUISH
①	Network configuration indicator	Configuring Network	SmartLink configuring	Done
②	Router connection indicator	Normal	Abnormal	----
③	Cloud server connection indicator	Normal	Abnormal	----
④	485 communication indicator	Normal	Abnormal	----

## Account Login

Use email address and password to register, login or reset the password.

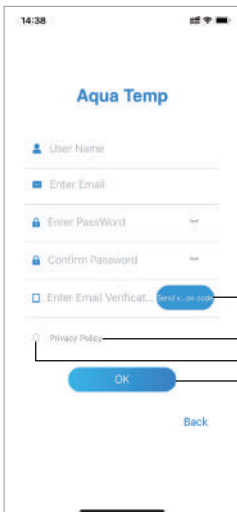

Fig.2 Account Registration interface

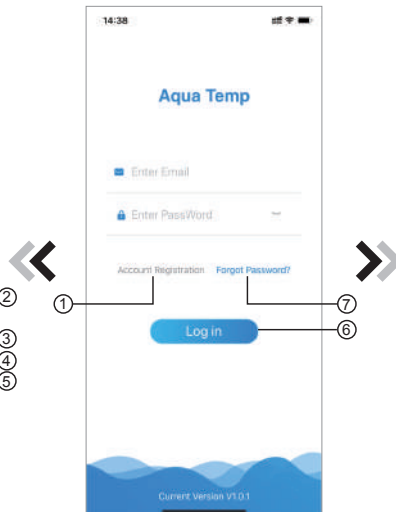

Fig.1 Login interface

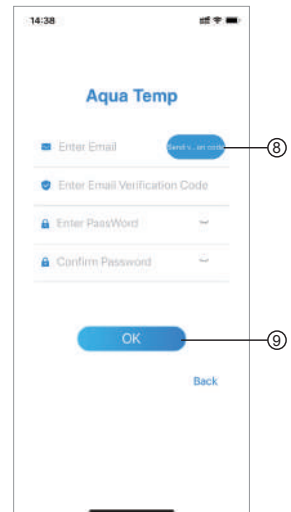

Fig.3 Forgot Password interface

## 5. Use and Operation Instruction of WIFI module

1. Account Registration: To register an account, click ① (Fig.1) to jump to the Account Registration interface, fill in the relevant information and click ② to receive verification code, while completed the application information, click ③ to read the details of the Privacy Policy, then click ④ to agree, and click ⑤, registration is done.

Please note, the valid time of one verification code is 15min, please fill in the verification code within 15min, otherwise you need to ask for a new one.

2. Log in: Follow the instructions on the page(Fig.1 ), enter your registered email address and password, click ⑥ and jump to device list;

3. Forgot Password: While forget your password, click ⑦ (Fig.1 ), jump to the Forgot Password interface (Fig.3 ). Follow the instructions on the page, fill in the relevant informations, click ⑧ to receive verification code from your mailbox, click ⑨ to confirm and password reset is done.

### Add Device

After log in, displays My Device interface (Fig. 4) , follow the instruction to add WIFI or DTU.

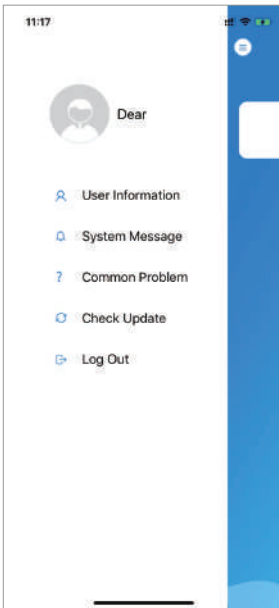

Fig.5 The left-hand menu



Fig.4 My Device interface

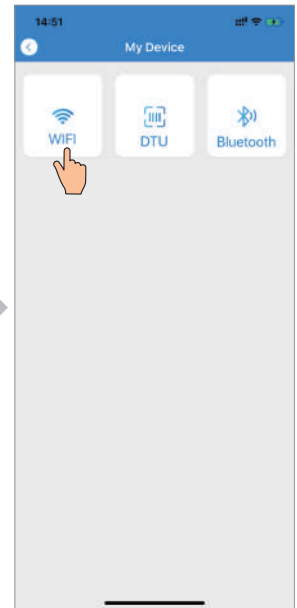

Fig.6 Add Device interface

# 5. Use and Operation Instruction of WIFI module

## WIFI Configure Network

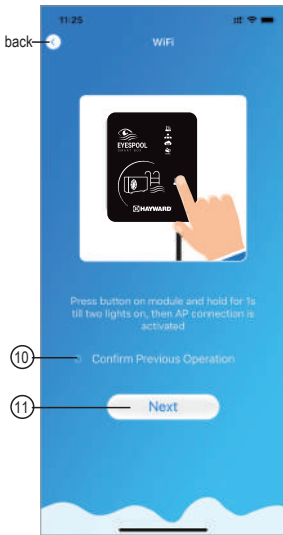

Fig.7 WIFI Module On interface

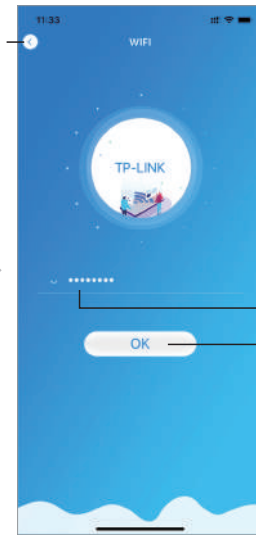

Fig.8 Enter password interface



Fig.9 Connect specified WIFI

1. Follow the instructions on the page (Fig.7), press button on module and hold for 1s till two lights on, then AP connection is activated, click ⑩ to confirm, click ⑪ to turn the page;
2. Click ⑫ to enter the WIFI password for the current connection, click ⑬ to confirm;
3. Jump to system settings, connect specified WIFI, click ⑭ to select the "Smart\_AP\_xxx", click ⑮ to popup window(Fig.10), follow the instruction and then jump to WIFI setting interface(Fig.11);

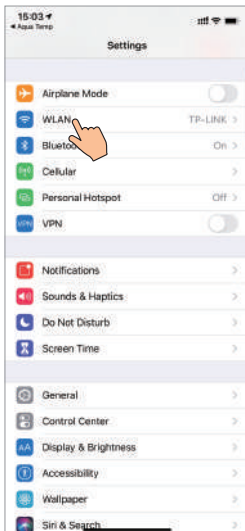

Fig.10 Setting interface

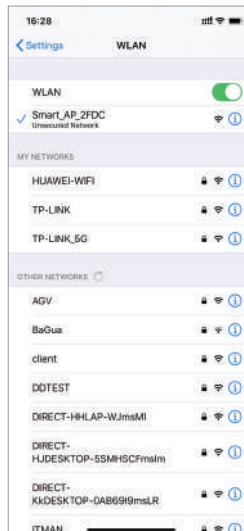

Fig.11 WIFI setting interface

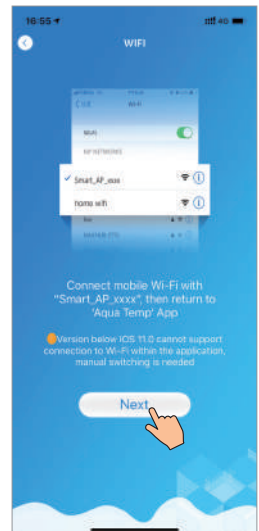

Fig.12 Connect specified WIFI

## 5. Use and Operation Instruction of WIFI module

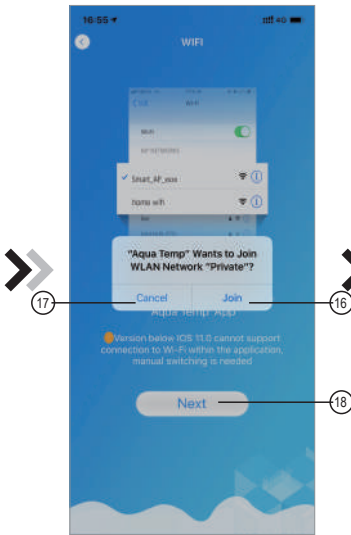

Fig.13 Configure Network interface

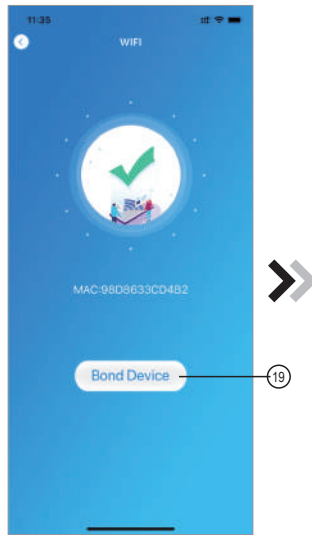

Fig.14 Bond Device interface

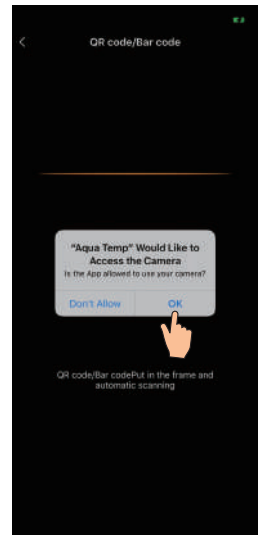

Fig.15 Scanning interface

- Slide the page back to configure network interface (Fig. 12), click (16) to join WLAN Network, click (17) to cancel, click (18) to turn next page(Fig. 13); click (19) to bond device (Fig. 14);
- Click "OK" (Fig.15) to allow the App to use the camera for scanning the **WF barcode** on the heat pump unit (Fig.16);
- Click "OK", device bond is done (Fig.17);
- After WIFI and DTU bonding is done, and jump back to My Device(Fig. 18).



Fig.16 WF barcode

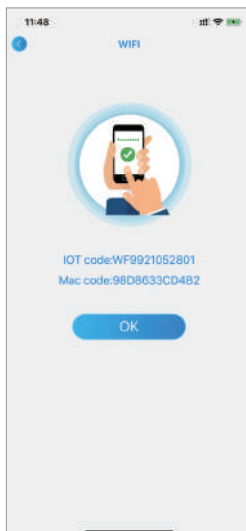

Fig.17 Bond device done interface

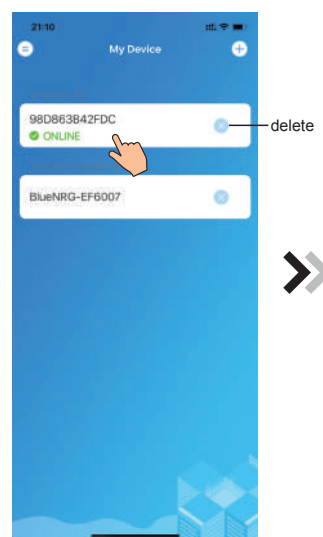

Fig.18 Device management interface

# 5. Use and Operation Instruction of WIFI module

## Device Management

Device management operations are as below :

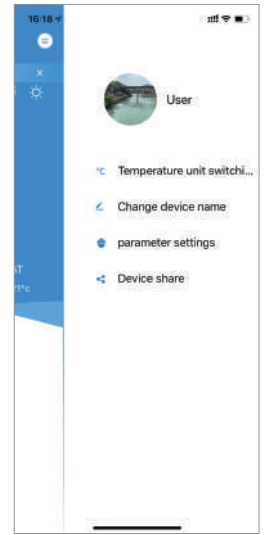
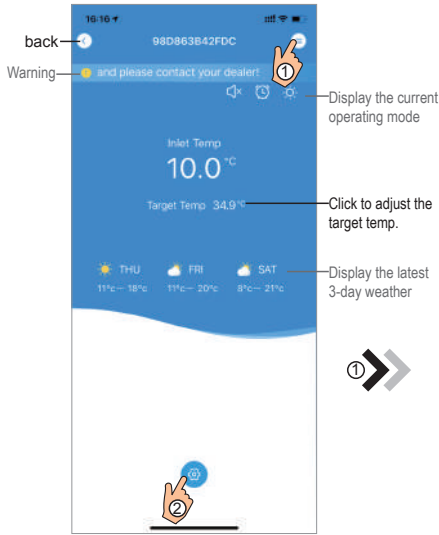

Fig.19 Device Main interface

Fig.20 The right-hand menu interface

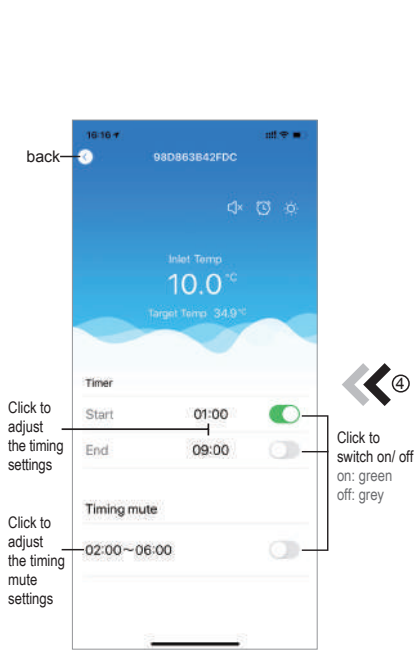

Fig.22 Timing Settings interface

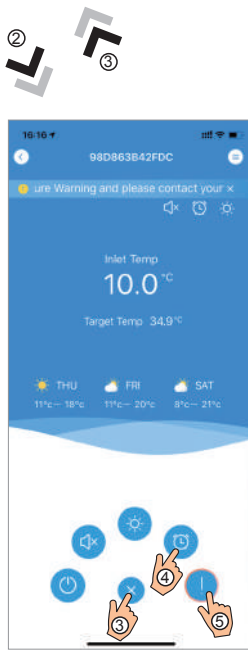

Fig.21 Device Main interface

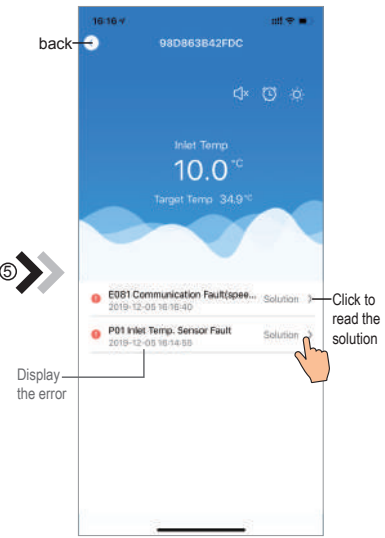











Fig.23 Troubleshooting interface

## 5. Use and Operation Instruction of WIFI module

ICON	NAME	FUNCTIONS
	ON/ OFF	Click it to turn on/ off the unit
	Silent Mode Off	Display silent mode off, click it to activate the silent mode
	Silent Mode On	Display silent mode on, click it to turn off the silent mode
	Mode shift	Mode changing: Cooling--Heating--Auto
	Cooling	Display Cooling mode, click it to change operating mode
	Heating	Display Heating mode, click it to change operating mode
	Auto	Display Auto mode, click it to change operating mode
	Timming settings	Click it to jump to the timer on/ off and mute timer setting interface
	Troubleshooting	Click it to jump to the troubleshooting interface
	Menu	Click to unfold or collapse the menu

## 6. MAINTENANCE AND INSPECTION

---

- Check the water supply device and the release often. You should avoid the condition of no water or air entering into system, as this will influence unit's performance and reliability. You should clear the pool/spa filter regularly to avoid damage to the unit as a result of the dirty or clogged filter.
- The area around the unit should be dry, clean and well ventilated. Clean the side heating exchanger regularly to maintain good heat exchange as conserve energy .
- The operation pressure of the refrigerant system should only be serviced by a certified technician .
- Check the power supply and cable connection often, .Should the unit begin to operate abnormally, switch it off and contact the qualified technician.
- Discharge all water in the water pump and water system ,so that freezing of the water in the pump or water system does not occur. You should discharge the water at the bottom of water pump if the unit will not be used for an extended period of time. You should check the unit thoroughly and fill the system with water fully before using it for the first time after a prolonged period of no usage.
- Checks to the area  
Prior to beginning work on systems containing flammable refrigerants, safety checks are necessary to ensure that the risk of ignition is minimised. For repair to the refrigerating system, the following precautions shall be complied with prior to conducting work on the system.
- Work procedure  
Work shall be undertaken under a controlled procedure so as to minimise the risk of a flammable gas or vapour being present while the work is being performed.
- Work procedure  
Work shall be undertaken under a controlled procedure so as to minimise the risk of a flammable gas or vapour being present while the work is being performed.
- General work area  
All maintenance staff and others working in the local area shall be instructed on the nature of work being carried out. Work in confined spaces shall be avoided. The area around the workspace shall be sectioned off. Ensure that the conditions within the area have been made safe by control of flammable material.
- General work area  
All maintenance staff and others working in the local area shall be instructed on the nature of work being carried out. Work in confined spaces shall be avoided. The area around the workspace shall be sectioned off. Ensure that the conditions within the area have been made safe by control of flammable material.
- Checking for presence of refrigerant  
The area shall be checked with an appropriate refrigerant detector prior to and during work, to ensure the technician is aware of potentially flammable atmospheres. Ensure that the leak detection equipment being used is suitable for use with flammable refrigerants, i.e. non-sparking, adequately sealed or intrinsically safe.
- Presence of fire extinguisher  
If any hot work is to be conducted on the refrigeration equipment or any associated parts, appropriate fire extinguishing equipment shall be available to hand. Have a dry powder or CO2 fire extinguisher adjacent to the charging area.

## 6. MAINTENANCE AND INSPECTION

---

### ● No ignition sources

No person carrying out work in relation to a refrigeration system which involves exposing any pipe work that contains or has contained flammable refrigerant shall use any sources of ignition in such a manner that it may lead to the risk of fire or explosion. All possible ignition sources, including cigarette smoking, should be kept sufficiently far away from the site of installation, repairing, removing and disposal, during which flammable refrigerant can possibly be released to the surrounding space. Prior to work taking place, the area around the equipment is to be surveyed to make sure that there are no flammable hazards or ignition risks. “No Smoking” signs shall be displayed.

### ● Ventilated area

Ensure that the area is in the open or that it is adequately ventilated before breaking into the system or conducting any hot work. A degree of ventilation shall continue during the period that the work is carried out. The ventilation should safely disperse any released refrigerant and preferably expel it externally into the atmosphere. prolonged period of no usage.

### ● Checks to the area

Prior to beginning work on systems containing flammable refrigerants, safety checks are necessary to ensure that the risk of ignition is minimised. For repair to the refrigerating system, the following precautions shall be complied with prior to conducting work on the system. prolonged period of no usage.

### ● Checks to the refrigeration equipment

Where electrical components are being changed, they shall be fit for the purpose and to the correct specification. At all times the manufacturer's maintenance and service guidelines shall be followed. If in doubt consult the manufacturer's technical department for assistance.

The following checks shall be applied to installations using flammable refrigerants:

The charge size is in accordance with the room size within which the refrigerant containing parts are installed;

The ventilation machinery and outlets are operating adequately and are not obstructed;

If an indirect refrigerating circuit is being used, the secondary circuit shall be checked for the presence of refrigerant;

Marking to the equipment continues to be visible and legible. Markings and signs that are illegible shall be corrected;

Refrigeration pipe or components are installed in a position where they are unlikely to be exposed to any substance which may corrode refrigerant containing components, unless the components are constructed of materials which are inherently resistant to being corroded or are suitably protected against being so corroded.

### ● Checks to electrical devices

Repair and maintenance to electrical components shall include initial safety checks and component inspection procedures. If a fault exists that could compromise safety, then no electrical supply shall be connected to the circuit until it is satisfactorily dealt with. If the fault cannot be corrected immediately but it is necessary to continue operation, an adequate temporary solution shall be used. This shall be reported to the owner of the equipment so all parties are advised.

Initial safety checks shall include:

. That capacitors are discharged: this shall be done in a safe manner to avoid possibility of sparking;

. That there no live electrical components and wiring are exposed while charging, recovering or purging the system;

. That there is continuity of earth bonding.

## 6. MAINTENANCE AND INSPECTION

---

### ● Repairs to sealed components

1) During repairs to sealed components, all electrical supplies shall be disconnected from the equipment being worked upon prior to any removal of sealed covers, etc. If it is absolutely necessary to have an electrical supply to equipment during servicing, then a permanently operating form of leak detection shall be located at the most critical point to warn of a potentially hazardous situation.

2) Particular attention shall be paid to the following to ensure that by working on electrical components, the casing is not altered in such a way that the level of protection is affected. This shall include damage to cables, excessive number of connections, terminals not made to original specification, damage to seals, incorrect fitting of glands, etc.

Ensure that apparatus is mounted securely.

Ensure that seals or sealing materials have not degraded such that they no longer serve the purpose of preventing the ingress of flammable atmospheres. Replacement parts shall be in accordance with the manufacturer's specifications.

NOTE: The use of silicon sealant may inhibit the effectiveness of some types of leak detection equipment. Intrinsically safe components do not have to be isolated prior to

### ● Repair to intrinsically safe components

Do not apply any permanent inductive or capacitance loads to the circuit without ensuring that this will not exceed the permissible voltage and current permitted for the equipment in use.

Intrinsically safe components are the only types that can be worked on while live in the presence of a flammable atmosphere. The test apparatus shall be at the correct rating.

Replace components only with parts specified by the manufacturer. Other parts may result in the ignition of refrigerant in the atmosphere from a leak.

### ● Cabling

Check that cabling will not be subject to wear, corrosion, excessive pressure, vibration, sharp edges or any other adverse environmental effects. The check shall also take into account the effects of aging or continual vibration from sources such as compressors or fans.

### ● Detection of flammable refrigerants

Under no circumstances shall potential sources of ignition be used in the searching for or detection of refrigerant leaks. A halide torch (or any other detector using a naked flame) shall not be used.

### ● Leak detection methods

The following leak detection methods are deemed acceptable for systems containing flammable refrigerants.

Electronic leak detectors shall be used to detect flammable refrigerants, but the sensitivity may not be adequate, or may need re-calibration. (Detection equipment shall be calibrated in a refrigerant-free area.) Ensure that the detector is not a potential source of ignition and is suitable for the refrigerant used. Leak detection equipment shall be set at a percentage of the LFL of the refrigerant and shall be calibrated to the refrigerant employed and the appropriate percentage of gas (25 % maximum) is confirmed.

Leak detection fluids are suitable for use with most refrigerants but the use of detergents containing chlorine shall be avoided as the chlorine may react with the refrigerant and corrode the copper pipe-work.

If a leak is suspected, all naked flames shall be removed/ extinguished.

If a leakage of refrigerant is found which requires brazing, all of the refrigerant shall be recovered from the system, or isolated (by means of shut off valves) in a part of the system remote from the leak. Oxygen free nitrogen (OFN) shall then be purged through the system both before and during the brazing process.

## 6. MAINTENANCE AND INSPECTION

---

### ● Removal and evacuation

When breaking into the refrigerant circuit to make repairs or for any other purpose conventional procedures shall be used. However, it is important that best practice is followed since flammability is a consideration. The following procedure shall be adhered to:

- . Remove refrigerant;
- . Purge the circuit with inert gas;
- . Evacuate;
- . Purge again with inert gas;
- . Open the circuit by cutting or brazing.

The refrigerant charge shall be recovered into the correct recovery cylinders. The system shall be "flushed" with OFN to render the unit safe. This process may need to be repeated several times. Compressed air or oxygen shall not be used for this task.

Flushing shall be achieved by breaking the vacuum in the system with OFN and continuing to fill until the working pressure is achieved, then venting to atmosphere, and finally pulling down to a vacuum. This process shall be repeated until no refrigerant is within the system. When the final OFN charge is used, the system shall be vented down to atmospheric pressure to enable work to take place. This operation is absolutely vital if brazing operations on the pipe-work are to take place.

Ensure that the outlet for the vacuum pump is not close to any ignition sources and there is ventilation available. Working on them.

### ● Labelling

Equipment shall be labelled stating that it has been de-commissioned and emptied of refrigerant. The label shall be dated and signed. Ensure that there are labels on the equipment stating the equipment contains flammable refrigerant.

### ● Recovery

When removing refrigerant from a system, either for servicing or decommissioning, it is recommended good practice that all refrigerants are removed safely.

When transferring refrigerant into cylinders, ensure that only appropriate refrigerant recovery cylinders are employed. Ensure that the correct number of cylinders for holding the total system charge is available. All cylinders to be used are designated for the recovered refrigerant and labelled for that refrigerant (i.e. special cylinders for the recovery of refrigerant). Cylinders shall be complete with pressure relief valve and associated shut-off valves in good working order. Empty recovery cylinders are evacuated and, if possible, cooled before recovery occurs.

The recovery equipment shall be in good working order with a set of instructions concerning the equipment that is at hand and shall be suitable for the recovery of flammable refrigerants. In addition, a set of calibrated weighing scales shall be available and in good working order. Hoses shall be complete with leak-free disconnect couplings and in good condition. Before using the recovery machine, check that it is in satisfactory working order, has been properly maintained and that any associated electrical components are sealed to prevent ignition in the event of a refrigerant release. Consult manufacturer if in doubt.

The recovered refrigerant shall be returned to the refrigerant supplier in the correct recovery cylinder, and the relevant Waste Transfer Note arranged. Do not mix refrigerants in recovery units and especially not in cylinders.

If compressors or compressor oils are to be removed, ensure that they have been evacuated to an acceptable level to make certain that flammable refrigerant does not remain within the lubricant. The evacuation process shall be carried out prior to returning the compressor to the suppliers. Only electric heating to the compressor body shall be employed to accelerate this process. When oil is drained from a system, it shall be carried out safely.

## 6. MAINTENANCE AND INSPECTION

---

### ● Decommissioning

Before carrying out this procedure, it is essential that the technician is completely familiar with the equipment and all its detail. It is recommended good practice that all refrigerants are recovered safely. Prior to the task being carried out, an oil and refrigerant sample shall be taken in case analysis is required prior to re-use of reclaimed refrigerant. It is essential that electrical power is available before the task is commenced.

- a) Become familiar with the equipment and its operation.
- b) Isolate system electrically.
- c) Before attempting the procedure ensure that:
  - . Mechanical handling equipment is available, if required, for handling refrigerant cylinders;
  - . All personal protective equipment is available and being used correctly;
  - . The recovery process is supervised at all times by a competent person;
  - . Recovery equipment and cylinders conform to the appropriate standards.
- d) Pump down refrigerant system, if possible.
- e) If a vacuum is not possible, make a manifold so that refrigerant can be removed from various parts of the system.
- f) Make sure that cylinder is situated on the scales before recovery takes place.
- g) Start the recovery machine and operate in accordance with manufacturer's instructions.
- h) Do not overfill cylinders. (No more than 80 % volume liquid charge).
- i) Do not exceed the maximum working pressure of the cylinder, even temporarily.
- j) When the cylinders have been filled correctly and the process completed, make sure that the cylinders and the equipment are removed from site promptly and all isolation valves on the equipment are closed off.
- k) Recovered refrigerant shall not be charged into another refrigeration system unless it has been cleaned and checked.

### ● Charging procedures

In addition to conventional charging procedures, the following requirements shall be followed.

- Ensure that contamination of different refrigerants does not occur when using charging equipment. Hoses or lines shall be as short as possible to minimise the amount of refrigerant contained in them.
- Cylinders shall be kept upright.
- Ensure that the refrigeration system is earthed prior to charging the system with refrigerant.
- Label the system when charging is complete (if not already).
- Extreme care shall be taken not to overfill the refrigeration system.

Prior to recharging the system it shall be pressure tested with OFN. The system shall be leak tested on completion of charging but prior to commissioning. A follow up leak test shall be carried out prior to leaving the site.

- The safety wire model is 5\*20\_5A/250VAC, And must meet the explosion-proof requirements

## 7. APPENDIX

---

### 7.1 Caution & Warning

1. The unit can only be repaired by qualified installer centre personnel or an authorised dealer. (for Europe market)
2. This appliance is not intended for use by persons (including children) with reduced physical sensory or mental capabilities, or lack of experience and knowledge, unless they have been given supervision or instruction concerning use of the appliance by a person responsible for their safety. (for Europe market)  
Children should be supervised to ensure that they do not play with the appliance.
3. Please make sure that the unit and power connection have good earthing, otherwise may cause electrical shock.
4. If the supply cord is damaged, it must be replaced by the manufacturer or our service agent or similarly qualified person in order to avoid a hazard.
5. Directive 2002/96/EC (WEEE):  
The symbol depicting a crossed-out waste bin that is underneath the appliance indicates that this product, at the end of its useful life, must be handled separately from domestic waste, must be taken to a recycling centre for electric and electronic devices or handed back to the dealer when purchasing an equivalent appliance.
6. Directive 2002/95/EC (RoHS): This product is compliant with directive 2002/95/EC (RoHS) concerning restrictions for the use of harmful substances in electric and electronic devices.
7. The unit CANNOT be installed near the flammable gas. Once there is any leakage of the gas, fire can occur.
8. Make sure that there is a circuit breaker for the unit, lack of circuit breaker can lead to electrical shock or fire.
9. The heat pump located inside the unit is equipped with an over-load protection system. It does not allow for the unit to start for at least 3 minutes from a previous stoppage.
10. The unit can only be repaired by the qualified personnel of an installer center or an authorized dealer. (for North America market)
11. Installation must be performed in accordance with the NEC/CEC by authorized person only. (for North America market)
12. USE SUPPLY WIRES SUITABLE FOR 75°C.
13. Caution: Single wall heat exchanger, not suitable for potable water connection.

# 7. APPENDIX

## 7.2 Cable specification

### (1) Single phase unit

Nameplate maximum current	Phase line	Earth line	MCB	Creepage protector	Signal line
No more than 10A	2×1.5mm <sup>2</sup>	1.5mm <sup>2</sup>	20A	30mA less than 0.1 sec	n×0.5mm <sup>2</sup>
10~16A	2×2.5mm <sup>2</sup>	2.5mm <sup>2</sup>	32A	30mA less than 0.1 sec	
16~25A	2×4mm <sup>2</sup>	4mm <sup>2</sup>	40A	30mA less than 0.1 sec	
25~32A	2×6mm <sup>2</sup>	6mm <sup>2</sup>	40A	30mA less than 0.1 sec	
32~40A	2×10mm <sup>2</sup>	10mm <sup>2</sup>	63A	30mA less than 0.1 sec	
40~63A	2×16mm <sup>2</sup>	16mm <sup>2</sup>	80A	30mA less than 0.1 sec	
63~75A	2×25mm <sup>2</sup>	25mm <sup>2</sup>	100A	30mA less than 0.1 sec	
75~101A	2×25mm <sup>2</sup>	25mm <sup>2</sup>	125A	30mA less than 0.1 sec	
101~123A	2×35mm <sup>2</sup>	35mm <sup>2</sup>	160A	30mA less than 0.1 sec	
123~148A	2×50mm <sup>2</sup>	50mm <sup>2</sup>	225A	30mA less than 0.1 sec	
148~186A	2×70mm <sup>2</sup>	70mm <sup>2</sup>	250A	30mA less than 0.1 sec	
186~224A	2×95mm <sup>2</sup>	95mm <sup>2</sup>	280A	30mA less than 0.1 sec	

### (2) Three phase unit

Nameplate maximum current	Phase line	Earth line	MCB	Creepage protector	Signal line
No more than 10A	3×1.5mm <sup>2</sup>	1.5mm <sup>2</sup>	20A	30mA less than 0.1 sec	n×0.5mm <sup>2</sup>
10~16A	3×2.5mm <sup>2</sup>	2.5mm <sup>2</sup>	32A	30mA less than 0.1 sec	
16~25A	3×4mm <sup>2</sup>	4mm <sup>2</sup>	40A	30mA less than 0.1 sec	
25~32A	3×6mm <sup>2</sup>	6mm <sup>2</sup>	40A	30mA less than 0.1 sec	
32~40A	3×10mm <sup>2</sup>	10mm <sup>2</sup>	63A	30mA less than 0.1 sec	
40~63A	3×16mm <sup>2</sup>	16mm <sup>2</sup>	80A	30mA less than 0.1 sec	
63~75A	3×25mm <sup>2</sup>	25mm <sup>2</sup>	100A	30mA less than 0.1 sec	
75~101A	3×25mm <sup>2</sup>	25mm <sup>2</sup>	125A	30mA less than 0.1 sec	
101~123A	3×35mm <sup>2</sup>	35mm <sup>2</sup>	160A	30mA less than 0.1 sec	
123~148A	3×50mm <sup>2</sup>	50mm <sup>2</sup>	225A	30mA less than 0.1 sec	
148~186A	3×70mm <sup>2</sup>	70mm <sup>2</sup>	250A	30mA less than 0.1 sec	
186~224A	3×95mm <sup>2</sup>	95mm <sup>2</sup>	280A	30mA less than 0.1 sec	

When the unit will be installed at outdoor, please use the cable which can against UV.

## 7.APPENDIX

---

### 7.3 Comparison table of refrigerant saturation temperature

Pressure (MPa )	0	0.3	0.5	0.8	1	1.3	1.5	1.8	2	2.3
Temperature (R410A)(°C)	-51.3	-20	-9	4	11	19	24	31	35	39
Temperature (R32)(°C)	-52.5	-20	-9	3.5	10	18	23	29.5	33.3	38.7
Pressure (MPa )	2.5	2.8	3	3.3	3.5	3.8	4	4.5	5	5.5
Temperature (R410A)(°C)	43	47	51	55	57	61	64	70	74	80
Temperature (R32)(°C)	42	46.5	49.5	53.5	56	60	62	67.5	72.5	77.4

# 7.APPENDIX

## 7.4 Exploded view and spare parts

Model and code:(1H-PASRW030SV113)

Model and code:(1H-PASRW040SV118 )

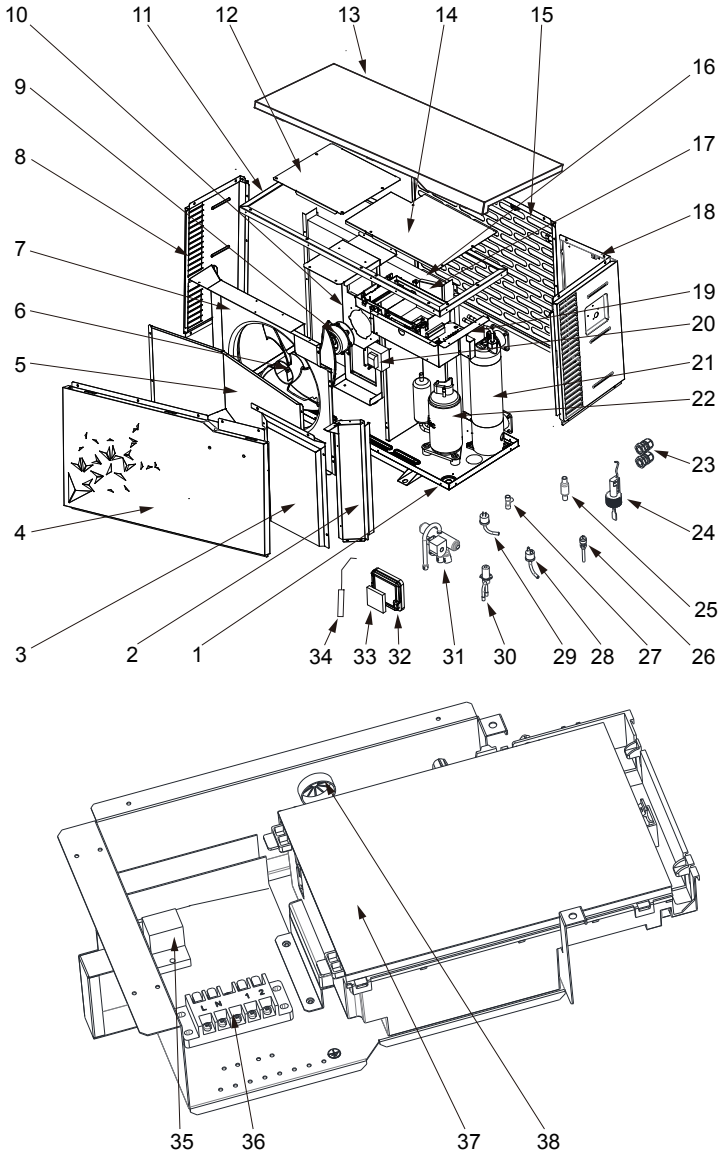

# 7.APPENDIX

Mark	Description	Ref.	100000000168	100000000169
1	Chassis	80708591	✓	/
		80709972	/	✓
2	Bracket components	80709202	✓	/
		80709989	/	✓
3	Dividers	80709204	✓	/
4	Front panel	80715842	✓	n/a
		80715857	n/a	✓
5	The wind deflector	80708605	✓	n/a
		80709986	n/a	✓
6	Fan blade	301030-00000006	✓	n/a
		20000-270004	n/a	✓
7	Air Guide coil assembly	80707103	✓	/
		80707730	/	✓
8	Left panel	80714313	✓	n/a
		80714308	n/a	✓
9	DC ventilator motor	80200018	✓	n/a
		20000-330132	n/a	✓
10	Motor bracket	80708597	✓	n/a
		80709977	n/a	✓
11	Top Box Component	80708593	✓	/
		80709976	/	✓
12	Left top plate	80711435	✓	/
		80711447	/	✓
13	Top cover	80717056	✓	n/a
		80709984	n/a	✓
14	Plate of electrical box	80708602	✓	n/a
		80710005	n/a	✓
15	Back panel	80710829	✓	n/a
		80710966	n/a	✓
16	Fin coil	80600781	✓	n/a
		80600835	n/a	✓
17	Middle Partition	80708599	✓	n/a
		80709987	n/a	✓
18	Right panel	80808955	✓	n/a
		80714307	n/a	✓
19	Electrical Box	80708596	✓	n/a
		80716023	n/a	✓
20	Reactance	82500020	✓	n/a
		82500021	n/a	✓
21	Titanium/PVC condenser	72300014	✓	/
		72300010	n/a	✓
22	Compressor	20000-110448	✓	n/a
		80100046	n/a	✓
23	Cable Gland	2001-2249	✓	n/a
		20012238	n/a	✓
24	Water flow detector	83000068	✓	✓
25	Filter Ø9.7-Ø9.7 (Ø19)	20000-140178	✓	n/a
		20041444	n/a	✓
26	Pressure tap 40mm-1/2"	20000-140150	✓	✓
27	Connector T Ø6.5-2 x Ø6.35(T) x 1.0	304030-00000002	✓	n/a
		2000-1460	n/a	✓
28	Low pressure switch NO 0.30MPa/0.15MPa	20000-360157	✓	✓
29	High pressure switch NC 3.2MPa/4.4MPa	2001-3605	✓	✓
30	Electronic expansion valve	81000011	✓	n/a
		81000017	n/a	✓
31	4 ways valve	2004-1437	✓	n/a
		20000-140485	n/a	✓
32	Controller mount	80901004	✓	✓
33	LCD Bluetooth® controller	72200312	✓	✓

NOTE: The Bluetooth® word mark and logos are registered trademarks owned by Bluetooth SIG, Inc. and any use of such marks by Hayward Industries, Inc is under license. Other trademarks and trade names are those of their respective owners.

# 7.APPENDIX

Mark	Description	Ref.	100000000168	100000000169
34	Water outlet sensor 5k-410mm	83000050	✓	✓
	Water inlet sensor 5k-850mm	83000052	✓	✓
	Compressor discharge probe 50k-660mm	83000026	✓	✓
	Compressor aspiration sensor 5k-560mm	83000044	✓	n/a
	Compressor aspiration sensor 5k-760mm	83000053	n/a	✓
	De-icing sensor 5k-680mm	83000051	✓	n/a
	De-icing sensor 5k-1040mm	83000045	n/a	✓
	Temperature sensor 5k-350mm	83000049	✓	✓
35	K2 relay	20000-360297	✓	✓
36	Terminal block L-N-GND -5 connections 4mm <sup>2</sup>	4000-3901	✓	✓
		72200168	✓	n/a
37	Printed circuit board Driver	72200167	n/a	✓
		80900768	✓	✓
38	Thread jacket	80900768	✓	✓

# 7.APPENDIX

Model and code:(1H-PASRW050SV120 )

1 Complete machine structure explosion diagram

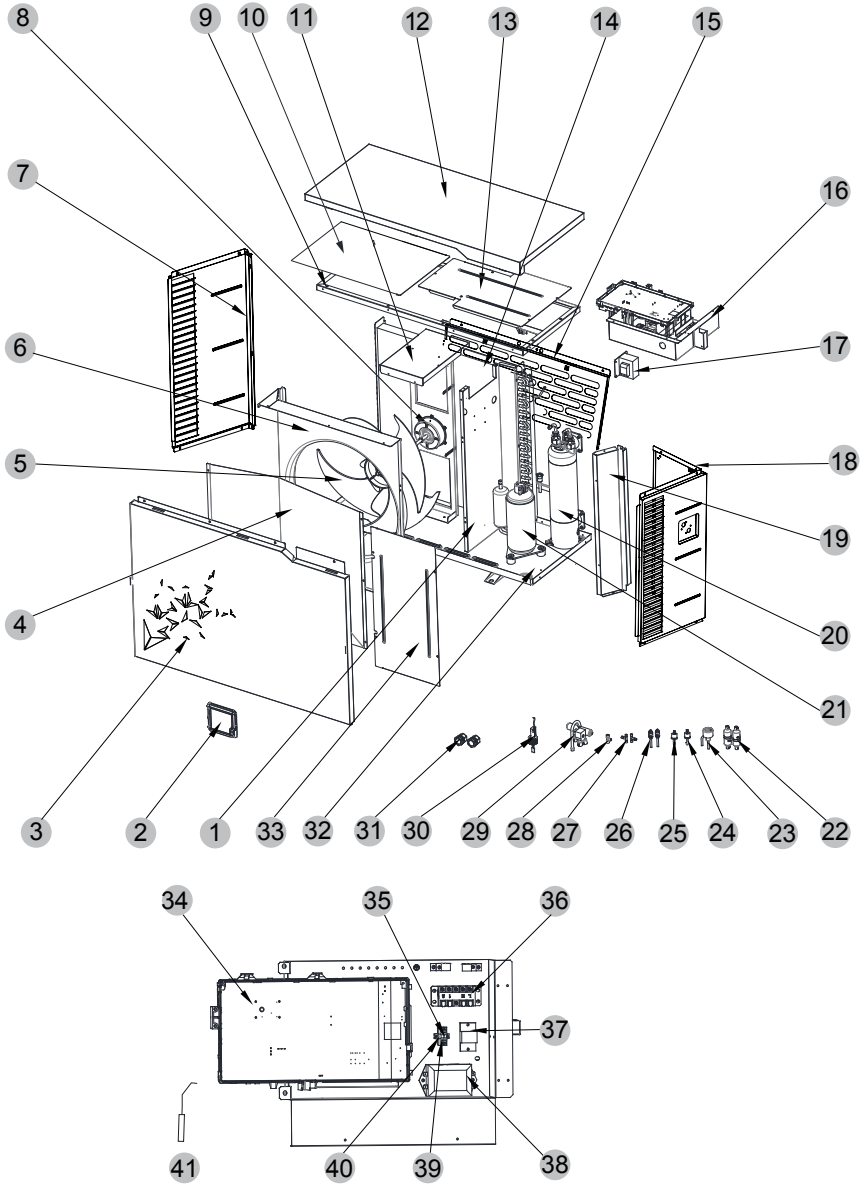

## 7.APPENDIX

No.	Code	Name	Specifications	Qty
1	80710057	Median septum	DX51D+Z80 t1.2 Black 9005	1
2	72200312	LCD300	26300114+82400109	1
3	80721846	Front panel	White glossy 9010 Gray Frosted 7043	1
4	80710055	Wind deflector	DX51D+Z80 t1.0 Black 9005	1
5	20000-270004	Fan blade	Z500-145	1
6	80708463	Wind deflector panel	Black gloss 9005	1
7	80721848	Left panel	DX51D+Z80 t1.0 Grey 7043	1
8	20000-330132	Fan motor	ZWS75-A	1
9	80710049	Top frame assembly	Black gloss 9005	1
10	80711446	Support plate	DX51D+Z80 t1.0 Black 9005	1
11	80710053	Fan motor bracket	Black gloss 9005	1
12	80710059	Top cover	DX51D+Z80 t1.0 Grey 7043	1
13	80710060	Support plate	DX51D+Z80 t1.0 Black 9005	1
14	80600836	Fin Heat Exchanger	714×800×Φ7×2 1.8	1
15	80710971	Back net	Grey frosted 7043	1
16	80710052	Electrical box	Black gloss 9005	1
17	82500021	Reactor	EL205FN	1
18	80721847	Right panel	DXGrey frosted 7043	1
19	80710058	Stand column	DX51D+Z80 t1.2 Black 9005	1
20	72300024	Titanium Tube Heat Exchanger	Φ12.7×10m Φ160	1
21	80100046	Compressor	SVB220FLGMC-L	1
22	2004-1444	Filter	Φ9.7-Φ9.7 (Φ28) T2Y2	2
23	81000017	Electronic Expansion Valve	DPF(TS1)2.0C-03	1
24	20000-360157	Low pressure switch	0.30MPa/0.15MPa ±0.05	1
25	2001-3605	High pressure switch	3.2MPa/4.4MPa ±0.15	1
26	20000-140150	Needle valve	40mm 1/2"	2
27	2000-1460	Tee-joints	Φ6.5-2×Φ6.5(T)×0.75 T2M	2
28	304030-00000002	Tee-joints	Φ9.52-2×Φ6.35(T)×1.0	1
29	20000-140485	Reversing Valve	DSF-11E-1030	1
30	83000068	Water flow switch	PSL-1 3/4	1
31	2001-2238	Waterproof wire sheath	PG21	2
32	80710047	Chassis	Grey frosted 7043	1
33	80710388	Partition	DX51D+Z80 t1.0 Black 9005	1



# 7.APPENDIX

Model and code:(1H-PASRW060SV124)

1 Complete machine structure explosion diagram

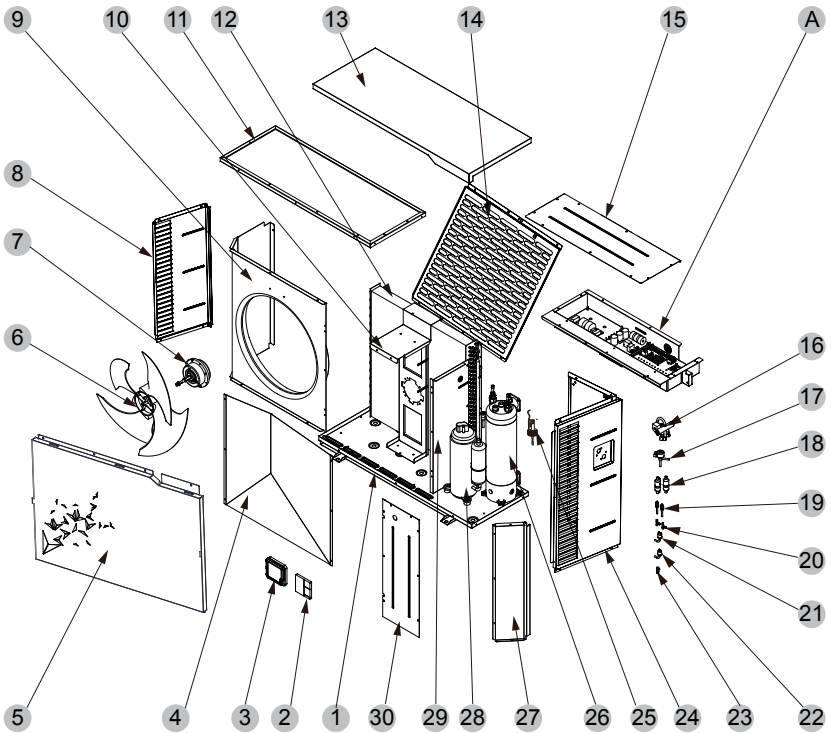

2 Electrical control structure explosion diagram

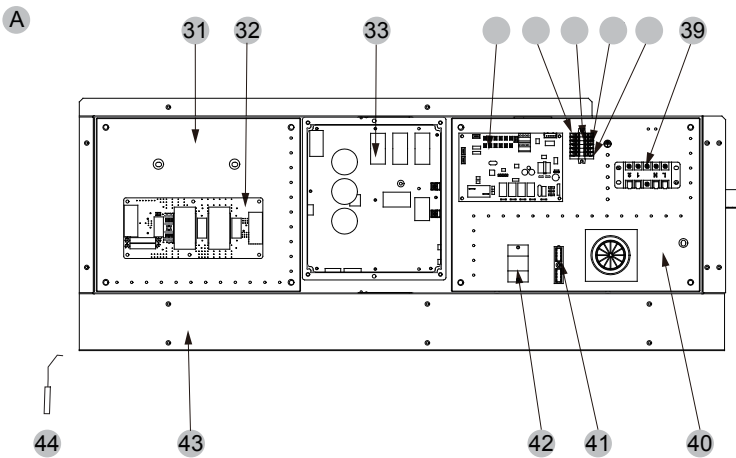

## 7.APPENDIX

No.	Code	Name	Specifications	Qty
1	80715646	Chassis component	Frosted gray 7043	1
2	72200312	LCD300 Display	26300114+82400109	1
3	80901004	Waterproof box	Tawny PC	1
4	80715026	Air deflector	Black 9005	1
5	80721846	Front panel	White glossy 9010 Gray Frosted 7043	1
6	301030-00000003	Axial fan blades	$\Phi 551 \times 160 - \Phi 12(10) \times 4$	1
7	20000-330309	Dc motor	ZWS150-F2	1
8	80721848	Left side plate	Frosted gray 7043	1
9	80713662	Wind deflector component	Black 9005	1
10	80715647	Motor holder component	Black 9005	1
11	80715648	Topstrap component	Black 9005	1
12	80601509	Finned heat exchanger	$714 \times 800 \times \Phi 7 \times 3$	1
13	80710059	Top cap	Frosted gray 7043	1
14	80710971	Back net component	Frosted gray 7043	1
15	80715656	Electric box cover	Black 9005	1
16	2004-1437	Four-way valve	DSF-11E-1030	1
17	20000-140575	Electronic expansion valve	DPF(B)3.0C-013	1
18	2004-1444	Filter	$\Phi 9.7 - \Phi 9.7 (\Phi 28) T2Y2$	2
19	20000-140150	Needle valve	FJ-3375-DG4	2
20	2000-1460	Three-way valve	$\Phi 6.5 - 2 \times \Phi 6.5(T) \times 0.75 T2M$	2
21	2001-3605	Pressure switch	$3.2MPa/4.4MPa \pm 0.15$	1
22	20000-360157	Pressure switch	$0.30MPa/0.15MPa \pm 0.05$	1
23	304030-00000002	Three-way valve	$\Phi 9.52 - 2 \times \Phi 6.35(T) \times 1.0$	1
24	80721847	Right side plate	Frosted gray 7043	1
25	83000069	Water flow switch	PSL-1 3/4	1
26	72300134	Titanium tube heat exchanger	$\Phi 16 \times 7.3m + \Phi 12.7 \times 4.7m \Phi 160$	1
27	80715654	Holder	Black 9005	1
28	80100069	Compressor	9VD330XAB21	1
29	80715652	Middle plate	Black 9005	1
30	80715653	Dummy plate	Black 9005	1
31	80715657	Scaleboard 1	Galvanized plate	1
32	82300342	Filter board	S.EMC.HPD120C.1	1
33	82300341	Inverter drive board	S.HPD120C.1	1



# 7.APPENDIX

Model and code:(1H-PASRW070SV128)

1 Complete machine structure explosion diagram

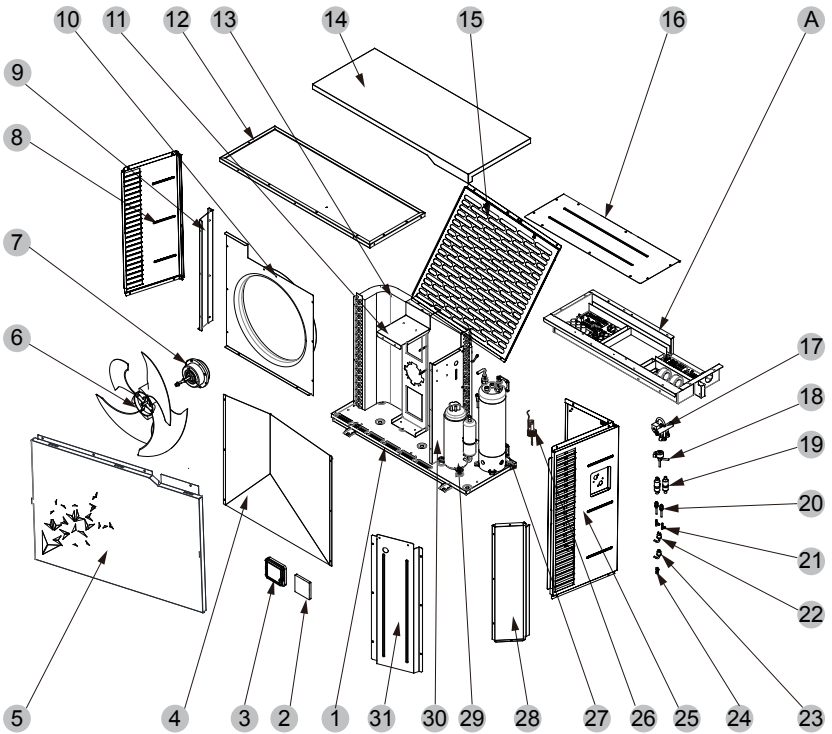

2 Electrical control structure explosion diagram

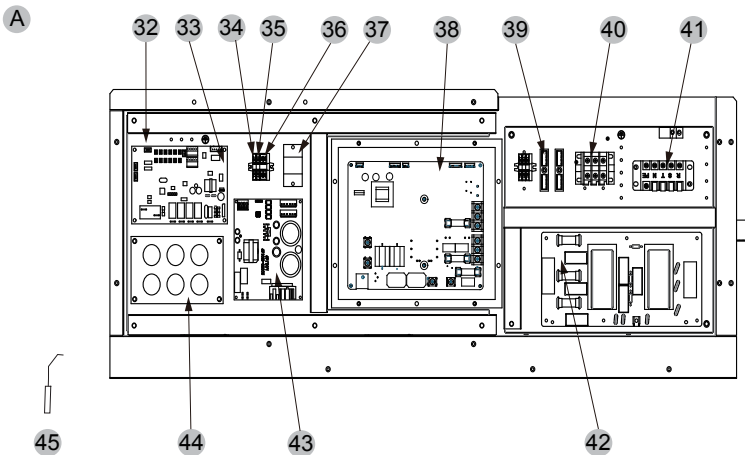

## 7.APPENDIX

No.	Code	Name	Specifications	Qty
1	80718971	Chassis component	Frosted gray 7043	1
2	72200312	LCD300	26300114+82400109	1
3	80901004	Waterproof box	Tawny PC	1
4	80715026	Air deflector	Black 9005	1
5	80721846	Front panel	Frosted gray 7043+White 9010	1
6	301030-00000003	Axial fan blades	$\Phi 551 \times 160 - \Phi 12(10) \times 4$	1
7	20000-330309	Dc motor	ZWS150-F2	1
8	80721848	Left side plate	Frosted gray 7043	1
9	80715766	Clapboard	Black 9005	1
10	80715765	Wind deflector component	Black 9005	1
11	80715770	Motor holder component	Black 9005	1
12	80710049	Topstrap component	Black 9005	1
13	80601520	Finned heat exchanger	$730 \times 220 \times 800 \times \Phi 7 \times 3$	1
14	80710059	Top cap	Frosted gray 7043	1
15	80710971	Back net component	Frosted gray 7043	1
16	80718969	Electric box cover	Black 9005	1
17	2004-1437	Four-way valve	DSF-11E-1030	1
18	81000084	Electronic expansion valve	HAM-BD28KFSZ-1	1
19	2004-1444	Filter	$\Phi 9.7 - \Phi 9.7 (\Phi 28) T2Y2$	2
20	20000-140150	Needle valve	FJ-3375-DG4	2
21	2000-1460	Three-way valve	$\Phi 6.5 - 2 \times \Phi 6.5(T) \times 0.75 T2M$	2
22	2001-3605	Pressure switch	$3.2MPa/4.4MPa \pm 0.15$	1
23	20000-360157	Pressure switch	$0.30MPa/0.15MPa \pm 0.05$	1
24	304030-00000002	Three-way valve	$\Phi 9.52 - 2 \times \Phi 6.35(T) \times 1.0$	1
25	80721847	Right side plate	Frosted gray 7043	1
26	83000069	Water flow switch	PSL-1 3/4	1
27	72300249	Titanium tube heat exchanger	$\Phi 16 \times 7.3m + \Phi 12.7 \times 5.7m \Phi 160$	1
28	80715654	Holder	Black 9005	1
29	80100133	Compressor	9VD420XAB21	1
30	80718966	Middle plate	Black 9005	1
31	80718970	Dummy plate	Black 9005	1
32	80718967	Scaleboard 1	DX51D+Z80 t0.8	1
33	72200451	PC1004-G Board	82300317+82400425	1



# KEEP THIS BOOKLET



Hayward Pool Products (Australia) Pty Ltd. Melbourne-Sydney-Brisbane-Perth  
Email: [sales@hayward-pool.com.au](mailto:sales@hayward-pool.com.au) | Website: [www.hayward-pool.com.au](http://www.hayward-pool.com.au)  
PO Box 4384 | Dandenong South VIC 3164  
ABN 66 083 413 414 Sales  
Contact Ph: 1300POOLS1 Fax: 1300POOLS2