



COMFORT MADE EASY.

Reliable efficient heating performance.

Specially designed to withstand the rigors of commercial operation, Universal H-Series ASME gas heaters include upgraded features and materials at no additional cost. By combining industry-leading hydraulics, energy efficiency and reliability with eco-friendly low NOx emissions, they provide the ideal heating solution for new or existing applications.

At the center is Hayward's Universal Display, delivering a consistent, intuitive control experience across Omni[®], OmniX[®], and competitive automation systems. Hayward Universal H-Series Heaters are ASME Certified for commercial use, meeting requirements in many states. Some states and local municipalities require gas heaters over a certain BTU output to be installed in a specific manner to meet code requirements. ***



PREMIUM FEATURES COME STANDARD

While other manufacturers pass on the costs for upgraded features, Universal H-Series ASME heaters include a cupro nickel heat exchanger, bronze header and an ASME pressure relief valve as standard. Plus, with a 3-year warranty on parts and labor, your customers will never be left in the cold.



BEST-IN-CLASS HEATING SPEED

Universal H-Series ASME heaters boast industry-leading hydraulics, with the 500,000 BTU model achieving the fastest speed-to-heat in its class. Its quick and efficient operation means you can achieve one million BTUs using just two heaters, conserving valuable pump room space and saving on installation costs.



FLEXIBLE INSTALLATION OPTIONS

With six model options to choose from, 2" x 2 1/2" CPVC plumbing fittings and independent left- or right-side electric, water and gas connections, there's a Universal H-Series ASME heater suited to every setup. Front single-panel access means service is quick and easy.





KEY FEATURES

- » **Mobile App remote access** for total control to program and diagnose issues. Be proactive instead of reactive to operating issues and enable quicker response times to get systems back up and running.
- » **One consistent user interface** and experience across all products with the built-in universal display that seamlessly connects with Hayward and competitive automation systems.
- » **Patented cupro nickel heat exchanger** with totally managed flow provides industry-best performance with powerful corrosion protection
- » **Universal plumbing, gas and electrical connections** offer quick and easy retrofitting and are certified for installation on combustible surfaces
- » **Electronic temperature lock-out** prevents unauthorized access to temperature settings
- » **24" high cabinet** is the lowest in the industry and can be raised off the floor if necessary
- » **Forced-draft combustion** produces low NOx emissions for and is certified for high-altitude applications up to 10,000 feet standard
- » **Fuse-protected circuit boards** make dual-voltage conversion safe and easy
- » **ASME pressure relief valve** comes standard to ensure system safety
- » **Noncorrosive feet** won't rust on wet pool pads
- » **Low-lead bronze header** with patented bypass design uses up to 18% less energy



OmniX Gateway sold separately, mobile phone not included.

DIMENSIONS

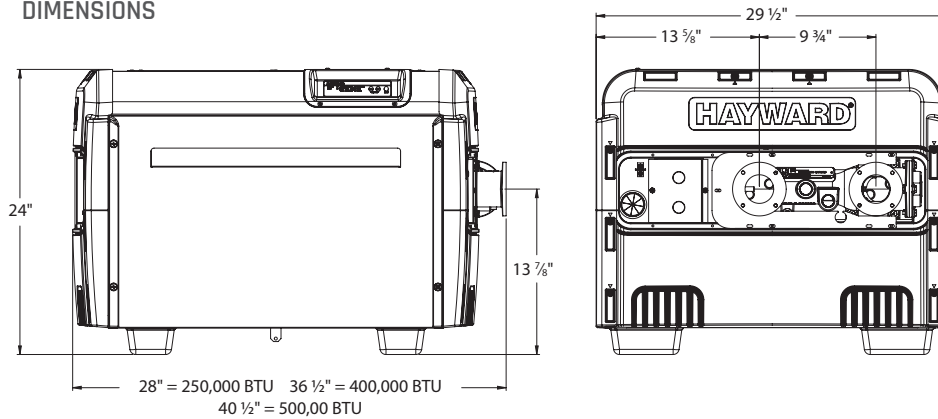

TECHNICAL SPECIFICATIONS AND PERFORMANCE DATA***

PART NUMBER	BTU	DESCRIPTION	PIPE SIZE	MAX. ALLOWED WORKING PRESSURE	FLOW RATE	DIMENSIONS (L X W X H)	CARTON QTY	CARTON WEIGHT
HS250FDNASME	250,000	Natural Gas	2" x 2 1/2"	125 PSI	25 - 125	28" x 29 1/2" x 24"	1	195 lbs.
HS400FDNASME	400,000	Natural Gas	2" x 2 1/2"	125 PSI	30 - 125	36 1/2" x 29 1/2" x 24"	1	225 lbs.
HS500FDNASME*	500,000	Natural Gas	2" x 2 1/2"	125 PSI	40 - 125	40 1/2" x 29 1/2" x 24"	1	240 lbs.
HS250FDPASME	250,000	Propane	2" x 2 1/2"	125 PSI	25 - 125	28" x 29 1/2" x 24"	1	195 lbs.
HS400FDPASME	400,000	Propane	2" x 2 1/2"	125 PSI	30 - 125	36 1/2" x 29 1/2" x 24"	1	225 lbs.
HS500FDPASME*	500,000	Propane	2" x 2 1/2"	125 PSI	40 - 125	40 1/2" x 29 1/2" x 24"	1	240 lbs.

ACCESSORIES***

PART NUMBER	DESCRIPTION	CARTON QTY	CARTON WEIGHT
UHXTFP1930	Texas Heater Kit - Temp/Pressure and Flow Switch Kit	1	5 lbs.
UHXFSW1930	Texas Heater Kit - Flow Switch Only	1	4 lbs.
W3GATEWAYX1	Optional OmniX Gateway	1	7.2 lbs.



Combination flow switch and temperature/pressure gauge

(included with 500,000 BTU model) ensures compliance with boiler and health code regulations (required for installation in certain markets).

*Includes flow and pressure sensor. [sku#: UHXTFP1930]

***Please consult your local gas heat appliance or boiler code to ensure compliance with state and local requirements and obtain the necessary permits for installation. Note that these heaters cannot be plumbed with solid metal pipe.

NEGATIVE PRESSURE VENT KITS

Part Number	Description	Heater Use	Indoor Vent Kit or Appliance Adaptor Use
UHXNEGVT12506	6" Negative Pressure Indoor VentKit	H250FDN/PASME	N/A
UHXNEGVT14008	8" Negative Pressure Indoor VentKit	H400FDN/PASME	N/A
UHXNEGVT15008	8" Negative Pressure Indoor VentKit	H500FDN/PASME	N/A

POSITIVE PRESSURE VENT KITS

Part Number	Description	Heater Use	Indoor Vent Kit or Appliance Adaptor Use
UHXPOSHZ12504**	4" Positive Pressure Indoor Vent Kit (No Appliance Adaptor Included)	H250FDN/PASME	Installer must chose: HeatFab (UHXHFA004) or Duravent (UHXDVA004)
UHXPOSHZ12506	6" Positive Pressure Indoor Vent Kit (Includes 6" HeatFab appliance adaptor)	H250FDN/PASME	Cannot be converted for use with Duravent Pipe
UHXPOSHZ14006**	6" Positive Pressure Indoor Vent Kit (No Appliance Adaptor Included)	H400FDN/PASME	Installer must chose: HeatFab (UHXHFA006) or Duravent (UHXDVA006)
UHXPOSHZ14008	8" Positive Pressure Indoor Vent Kit (Includes 8" HeatFab appliance adaptor)	H400FDN/PASME	Cannot be converted for use with Duravent Pipe
UHXPOSHZ15006**	6" Positive Pressure Indoor Vent Kit (No Appliance Adaptor Included)	H500FDN/PASME	Installer must chose: HeatFab (UHXHFA006) or Duravent (UHXDVA006)

APPLIANCE ADAPTORS (POSITIVE PRESSURE APPLICATIONS ONLY)

Part Number	Description	Heater Use	Indoor Vent Kit or Appliance Adaptor Use
UHXDVA004	4" Duravent Positive Pressure Appliance Adaptor	H250FDN/PASME	UHXPOSHZ12504
UHXDVA006	6" Duravent Positive Pressure Appliance Adaptor	H400FDN/PASME, H500FDN/PASME	UHXPOSHZ14006, UHXPOSHZ15006
UHXHFA004	4" HeatFab Positive Pressure Appliance Adaptor	H250FDN/PASME	UHXPOSHZ12504
UHXHFA006	6" HeatFab Positive Pressure Appliance Adaptor	H400FDN/PASME, H500FDN/PASME	UHXPOSHZ14006, UHXPOSHZ15006

HORIZONTAL POWER VENTING KITS

Part Number	Description
UHXNEGVM300	Horizontal Power Vent, Up to 300k BTU (Negative Pressure Application)
UHXNEGVM600	Horizontal Power Vent, Up to 610k BTU (Negative Pressure Application)

** The installer must choose an appliance adaptor that matches the vent pipe type used by the HVAC contractor. Confirm if it is HeatFab or Duravent, as these are the only vent types compatible with the heaters.



» haywardcommercialpool.com » 1-800-HAYWARD

Hayward, Hayward & Design, and the H logo, Omni and OmniX are registered trademarks of Hayward Industries, Inc. All other trademarks not owned by Hayward are the property of their respective owners. Hayward is not in any way affiliated with or endorsed by those third parties. ©2026 Hayward Industries, Inc.

CMUHSASMES26

 INNOVATION MADE EASY.