



We Build Better.™

TriStar® VS 950

Variable-Speed Pump

Pompe à vitesse variable

INDUSTRY-LEADING ENERGY EFFICIENCY
EFFICACITÉ ÉNERGÉTIQUE DE POINT



EXPERT LINE®



ONLY FROM POOL PROS



3+ YEAR PARTS WARRANTIES*

*Exclusions, other terms and conditions may apply — visit haywardpool.ca for details.

See-through strainer cover lets you see when the basket needs cleaning

Couvercle de la crépine transparent pour voir quand le panier de la crépine doit être nettoyé

Upgraded dual-voltage motor drive maintains optimal operating efficiency

Un moteur bitension mis à niveau maintient efficacité opérationnelle optimale



Wall-mountable touchpad control can be rotated in four directions

Interface de commande qui peut être installée au mur ou placée

Permanent magnet, totally enclosed fan-cooled motor offers more efficient operation and long-lasting reliability

Moteur fermé autoventilé à aimant permanent offer une efficacité énergétique fiable



INDUSTRY-LEADING ENERGY EFFICIENCY

TriStar VS 950 is the most energy-efficient residential pool pump on the market, according to EPA ENERGY STAR® third-party testing data.

La pompe TriStar VS 950 est la pompe pour piscine résidentielle la plus écoénergétique sur le marché selon les données de tests EPA ENERGY STAR® effectués par des tiers.



DESIGNED FOR DURABILITY

Built with a chemical-resistant Viton® seal and accompanied by a 3-year extended warranty,

Construite avec un joint d'étanchéité en Viton résistant aux produits chimiques et une garantie prolongée de 3 ans.



SEAMLESS RETROFITTING

With dual-voltage capabilities, two pump base options and 2" x 2½" CPVC union connections, TriStar VS 950 is easy to install in both new and existing pool pads and doesn't require costly rewiring.

Avec un moteur bitension mis à niveau, deux options de base pour la pompe et des raccords union de 2 po x 2½ po en CPVC, la pompe TriStar VS 950 s'installe facilement sur une piscine neuve ou une piscine déjà en place.



SPECIFICATIONS / SPÉCIFICATIONS

MODEL NUMBER	TOTAL HP	VOLTAGE	WEIGHTED ENERGY FACTOR (WEF)*	UNION CONNECTIONS	WARRANTY
SP32950VSP	2.7	115V/230V	10.1/7.3	2" x 2.5"	3 years**

TRISTAR VS 950 DIMENSIONS (INCHES) DIMENSIONS DE LA POMPE TRISTAR VS 950 (POUCES)

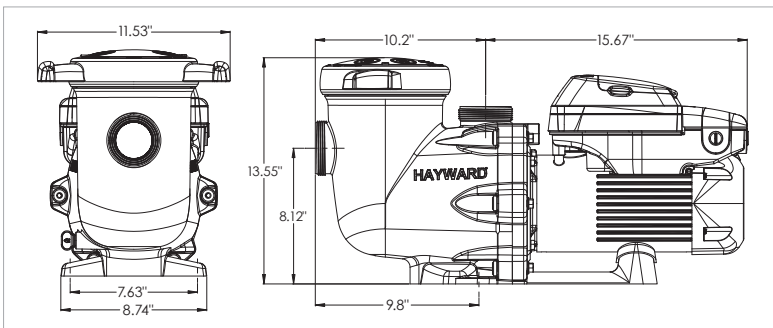

TRISTAR VS 950 PERFORMANCE COMPARISON

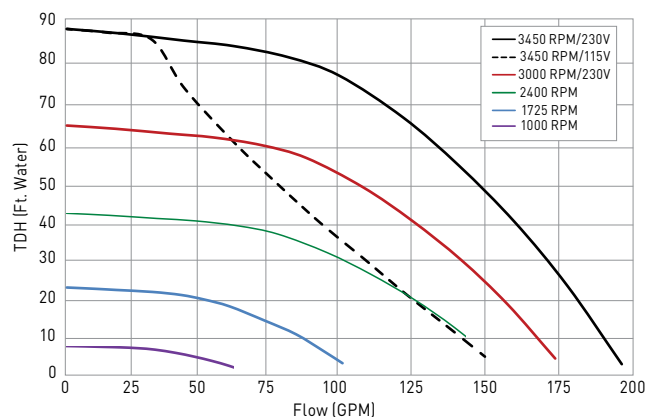

TriStar VS 950 pumps are listed by:

**Exclusions, other terms and conditions may apply — visit haywardpool.ca for details.

» haywardpool.ca » 1-888-238-7665

Pumps » Filters » Heaters » Sanitization » Automation » Lighting » Water Features » Cleaners » Safety

Hayward, Hayward & Design, the H logo, Totally Hayward, TriStar and We Build Better. are registered trademarks and Expert Line is a trademark of Hayward Canada and Hayward Industries, Inc. ENERGY STAR is a registered mark owned by the U.S. government. All other trademarks not owned by Hayward are the property of their respective owners. Hayward is not in any way affiliated with or endorsed by those third parties. © 2023 Hayward Industries, Inc.

LITTSVS95023C



We Build Better.™