

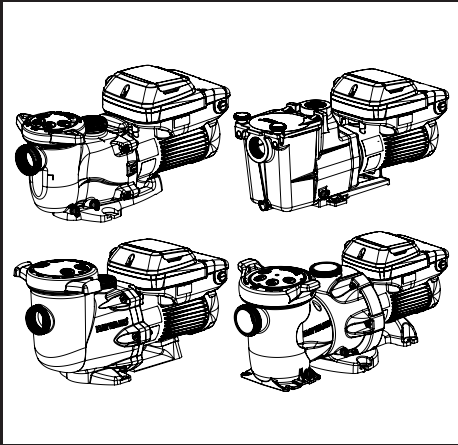

Hayward VS Pump Family

Owner's Manual

	Contents Safety Instructions.....1 Introduction.....4 Technical Specifications.....5 Installation.....10 Operation.....13 Display and Automation.....17 Maintenance.....24 Troubleshooting.....26 Replacement Parts.....28 Warranty.....34
--	---

MaxFlo VS	Super Pump VS	TriStar VS 1.85	TriStar VS 2.70	TriStar XL VS
SP23520VSPX1 W3SP2303VSPX1 SPX2303Z1VSPE	SP2670020VSPX1 W3SP2603VSPX1 SPX2603Z1VSPE	SP32900VSPX1 W3SP3202VSPX1 SPX3202Z1VSPE	HCP2500VSPX1 SP32950VSPX1 W3SP3206VSPX1 SPX3206Z1VSPE	HCP3020VSPX1 HCXP3020Z1VSPE

Hayward Industries
 1415 Vantage Park Dr., Suite 400
 Charlotte, NC 28203
 Phone (908)-355-7995
www.hayward.com





HAYWARD®

IMPORTANT SAFETY INSTRUCTIONS

Basic safety precautions should always be followed, including the following. Failure to follow instructions can cause severe injury and/or death.

 This is the safety-alert symbol. When you see this symbol on your equipment or in this manual, look for one of the following signal words and be alert to the potential for personal injury:

 **WARNING** - Warns about hazards that could cause serious personal injury, death or major property damage and if ignored presents a potential hazard.

 **CAUTION** - Warns about hazards that will or can cause minor or moderate personal injury and/or property damage and if ignored presents a potential hazard. It can also make consumers aware of actions that are unpredictable and unsafe.

NOTICE - Indicates special instructions that are important but not related to hazards.

 **WARNING – READ AND FOLLOW ALL INSTRUCTIONS** in this owner's manual and on the equipment. Failure to follow instructions can cause severe injury and/or death.

 **WARNING** – This product should be installed and serviced only by a qualified professional.

 **CAUTION** – All electrical wiring MUST be in conformance with all applicable local codes, regulations, and the National Electric Code (NEC).

ATTENTION INSTALLER – THIS MANUAL CONTAINS IMPORTANT INFORMATION ABOUT THE INSTALLATION, OPERATION, AND SAFE USE OF THIS VARIABLE SPEED PUMP THAT MUST BE FURNISHED TO THE END USER OF THIS PRODUCT. FAILURE TO READ AND FOLLOW ALL INSTRUCTIONS COULD RESULT IN SERIOUS INJURY.

 **WARNING** – To reduce risk of injury, do not permit children to use or climb on this product. Closely supervise children at all times. Components such as the filtration system, pumps, and heaters must be positioned to prevent children from using them as a means of access to the pool.

 **CAUTION** – This pump is intended for use on permanently installed swimming pools and may also be used with hot tubs and spas if so marked. Do NOT use with storable pools. A permanently installed pool is constructed in or on the ground or in a building such that it cannot be readily disassembled for storage. A storable pool is constructed so that it is capable of being readily disassembled for storage and reassembled to its original integrity. Though this product is designed for outdoor use, it is strongly advised to protect the electrical components from the weather. Select a well-drained area, one that will not flood when it rains. It requires free circulation of air for cooling. Do not install in a damp or non-ventilated location. If installed within an outer enclosure or beneath the skirt of a hot tub or spa, adequate ventilation and free circulation of air must be provided to prevent overheating of the motor.

 **WARNING** – Pool and spa components (seals, gaskets, etc.) have a finite life. All components should be inspected frequently and replaced at least every ten years, or if found to be damaged, broken, cracked, missing, or not securely attached.

 **WARNING – Risk of Electric Shock.** All electrical wiring MUST be in conformance with applicable local codes, regulations, and the National Electric Code (NEC). Hazardous voltage can shock, burn, and cause death or serious property damage. To reduce the risk of electric shock, do NOT use an extension cord to connect unit to electric supply. Provide a properly located electrical receptacle. Before working on the pump or motor, turn off power supply to the pump.

 **WARNING** – To reduce the risk of electric shock, replace damaged wiring immediately. Locate conduit to prevent abuse from lawn mowers, hedge trimmers and other equipment.





 **WARNING – Risk of Electric Shock.** In accordance with the National Electric Code (NEC), only connect to a branch circuit protected by a ground-fault circuit-interrupter (GFCI). Contact a qualified electrician if you cannot verify that the circuit is protected by a GFCI. The unit must be connected only to a supply circuit that is protected by a GFCI. Such a GFCI should be provided by the installer and should be tested on a routine basis. To test the GFCI, push the test circuit button. The GFCI should interrupt power. Push the reset button. Power should be restored. If the GFCI fails to operate in this manner, the GFCI is defective. If the GFCI interrupts power to the pump without the test button being pushed, a ground current is flowing, indicating the possibility of an electric shock. Do not use this pump. Disconnect the pump and have the problem corrected by a qualified service representative before using.



 **⚠ WARNING – Risk of Electric Shock.** Failure to bond pump to pool structure will increase risk for electrocution and could result in injury or death. To reduce the risk of electric shock, see installation instructions and consult a professional electrician on how to bond pump. Also, contact a licensed electrician for information on local electrical codes for bonding requirements.

Notes to electrician: Use a solid copper conductor, size 8 or larger. Run a continuous wire from external bonding lug to reinforcing rod or mesh. Connect a No. 8 AWG (8.4 mm²) [No. 6 AWG (13.3 mm²) for Canada] solid copper bonding wire to the pressure wire connector provided on the pump housing and to all metal parts of swimming pool, spa, or hot tub, and to all electrical equipment, metal piping (except gas piping), and conduit within 5 ft. (1.5 m) of inside walls of swimming pool, spa, or hot tub. **IMPORTANT** - Reference NEC codes for all wiring standards including, but not limited to, grounding, bonding and other general wiring procedures.

⚠ WARNING – Suction Entrapment Hazard. Suction in suction outlets and/or suction outlet covers, which are damaged, broken, cracked, missing, or unsecured cause severe injury and/or death due to the following entrapment hazards (symbols complements of APSP):

-  **Hair Entrapment** - Hair can become entangled in suction outlet cover.
-  **Limb Entrapment** - A limb inserted into an opening of a suction outlet sump or suction outlet cover that is damaged, broken, cracked, missing, or not securely attached can result in a mechanical bind or swelling of the limb.
-  **Body Suction Entrapment** - A differential pressure applied to a large portion of the body or limbs can result in an entrapment.
-  **Evisceration/Disembowelment** - A negative pressure applied directly to the intestines through an unprotected suction outlet sump or suction outlet cover which is damaged, broken, cracked, missing, or unsecured can result in evisceration/disembowelment.
-  **Mechanical Entrapment** - There is potential for jewelry, swimsuits, hair decorations, fingers, toes, or knuckles to be caught in an opening of a suction outlet cover resulting in mechanical entrapment.

⚠ WARNING – To Reduce the Risk of Entrapment Hazards:

- When outlets are small enough to be blocked by a person, a minimum of two functioning suction outlets per pump must be installed. Suction outlets in the same plane (i.e. floor or wall) must be installed a minimum of three feet (3') [0.91 meter] apart, as measured from near point to near point.
- Dual suction fittings shall be placed in such locations and distances to avoid “dual blockage” by a user.
- Dual suction fittings shall not be located on seating areas or on the backrest for such seating areas.
- The maximum system flow rate shall not exceed the values shown in the table under “Mounting the Pump” on page 10.
- Never use pool or spa if any suction outlet component is damaged, broken, cracked, missing, or not securely attached.
- Replace damaged, broken, cracked, missing, or not securely attached suction outlet components immediately.
- In addition to two or more suction outlets per pump installed in accordance with latest APSP standards and CPSC guidelines, follow all national, state, and local codes applicable.
- Installation of a vacuum release or vent system, which relieves entrapping suction, is recommended.

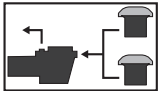

 **⚠ WARNING – Hazardous Pressure.** Pool and spa water circulation systems operate under hazardous pressure during start-up, normal operation, and after pump shut-off. Stand clear of circulation system equipment during pump start-up. Failure to follow safety and operation instructions could result in violent separation of the pump housing and cover due to pressure in the system, which could cause property damage, severe personal injury, or death. Before servicing pool and spa water circulation system, all system and pump controls must be in off position and filter manual air relief valve must be in open position. Before starting pump, all system valves must be set in a position to allow system water to return back to the pool. Do not change filter control valve position while pump is running. Before starting pump, fully open filter manual air relief valve. Do not close filter manual air relief valve until a steady stream of water (not air or air and water mix) is discharged from the valve. All suction and discharge valves **MUST** be OPEN when starting the circulation system. Failure to do so could result in severe personal injury and/or property damage.

 **⚠ WARNING – Separation Hazard.** Failure to follow safety and operation instructions could result in violent separation of pump components. Strainer cover must be properly secured to pump housing with strainer cover lock ring. Before servicing pool and spa circulation system, all system and pump controls must be in off position and filter manual air relief valve must be in open position. Do not operate pool and spa circulation system if a system component is not assembled properly, damaged, or missing. Do not operate pool and spa circulation system unless filter manual air relief valve body is in locked position in filter upper body. Never operate the circulation system at more than 50 psi maximum. All suction and discharge valves **MUST** be OPEN when starting the circulation system. Failure to do so could result in severe personal injury and/or property damage.

⚠ WARNING – Fire and burn hazard. Motors operate at high temperatures and if they are not properly isolated from any flammable structures or foreign debris they can cause fires, which may cause severe personal injury or death. It is also necessary to allow the motor to cool for at least 20 minutes prior to maintenance to minimize the risk for burns.

SAVE THESE INSTRUCTIONS



HAYWARD®

⚠ WARNING

- **INGESTION HAZARD:** This product contains a button cell or coin battery.
- **DEATH** or serious injury can occur if ingested.
- A swallowed button cell or coin battery can cause **Internal Chemical Burns** in as little as **2 hours**.
- **KEEP** new and used batteries **OUT OF REACH** or **CHILDREN**.
- **Seek immediate medical attention** if a battery is suspected to be swallowed or inserted inside any part of the body.



⚠ WARNING – Even used batteries may cause death or serious injury.

⚠ WARNING – Call a local poison control center for treatment information.

⚠ WARNING – Remove and immediately recycle or dispose of used batteries according to local regulations and keep away from children. Do NOT dispose of batteries in household trash or incinerate.

⚠ WARNING – This product contains non-rechargeable batteries. Do NOT force discharge, recharge, disassemble, heat above 85°C, or incinerate. Doing so may result in injury due to venting, leakage, or explosion resulting in chemical burns.

⚠ WARNING – This product contains non-replaceable batteries. Do NOT under any circumstances attempt to remove or replace the factory-installed battery.

⚠ WARNING – Non-rechargeable batteries are not to be recharged.

NOTICE – This product contains a Panasonic BR2032 coin-type lithium battery.

NOTICE – The nominal voltage of the battery contained within this product is 3V.

Certificate of Conformity

Product: MaxFlo®, Super Pump, and TriStar® Series Variable Speed Pumps

CPSC Regulation: Safety Standard for Button Cell or Coin Batteries and Consumer Products Containing Such Batteries
Underwriters Laboratories UL 4200A-2023

Manufacturer: Hayward Industries
1415 Vantage Park Drive, Suite 400, Charlotte, NC 28203
Technical Service Phone: (908) 355-7995

Manufacture Location: Hayward Industries, One Hayward Industrial Drive, Clemmons, NC 27012

Date Manufactured: The serial number is a 17 digit number
Example serial number: 21122305456789001
The 5th - 8th digits are the “year and month” of the date of manufacture
Example above is the 5th month of 2023

Tested By: Hayward Industries, One Industrial Drive, Clemmons, NC 27012
Phone: (908) 355-7995
Test Report: July 2025

I hereby certify that the finished product(s) covered by this certificate comply with the rules, bans, standards, and regulations stated herein, and that the information in this certificate is true and accurate to the best of my knowledge, information, and belief. I understand and acknowledge that it is a United States federal crime to knowingly and willfully make any materially false, fictitious, or fraudulent statement, representation, or omission on this certificate.

For FCC and IC Regulatory Information, use the display terminal to navigate to Menu > Legal Info.

Introduction

Tools Required



Wire Cutter
and Stripper



Phillips Head
Screwdriver



Small
Flat Head
Screwdriver



1/4" Hex
Head Socket
(Optional)

What's Included

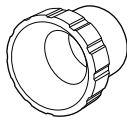
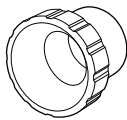

Union Connector Kit

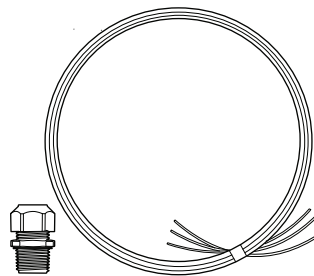

Communication Cable Kit

Includes:

- Cable (15 ft) (x1)
- Weather-proof fitting (x1)

Optional Accessories (Not Included)



OmniX Gateway
(W3GATEWAYX1)



Remote Mounted
Display Kit
(SPX3400DRKIT)

Includes:

- Mounting Plate (x1)
- Blank Cover Plate (x1)

Technical Specifications

MaxFlo VS Pump Dimensions

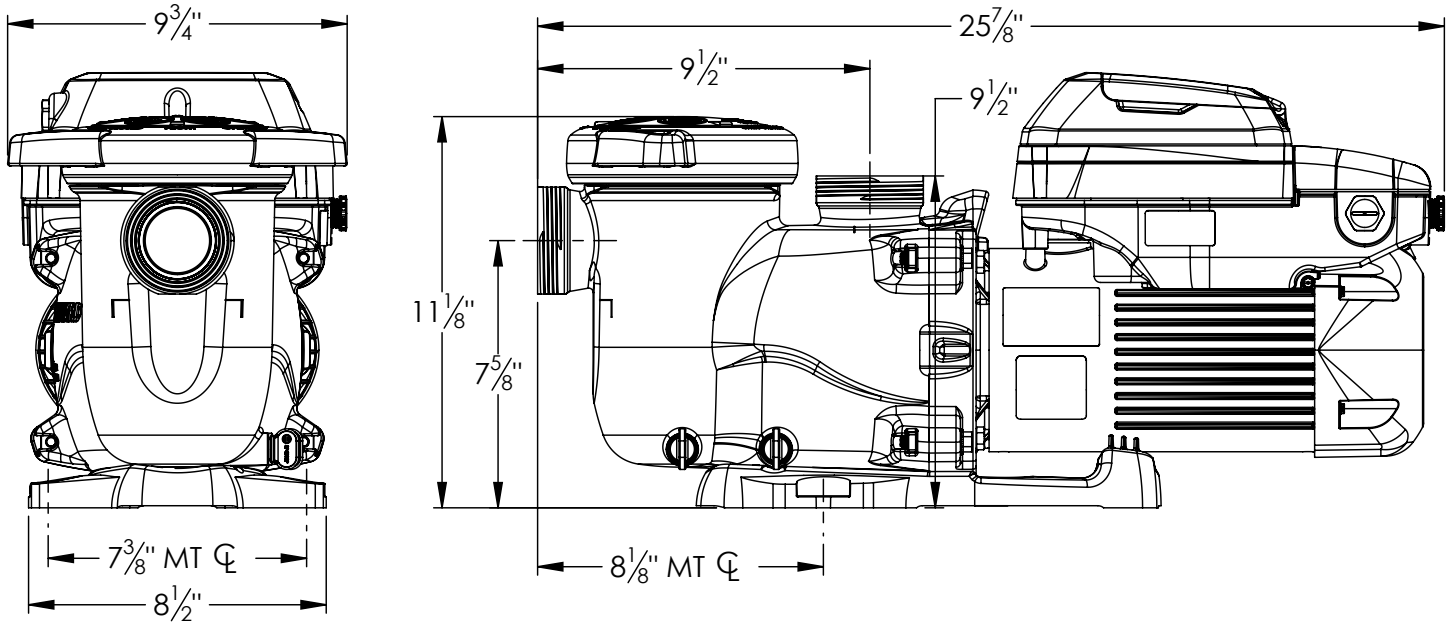

Pump Performance Curve

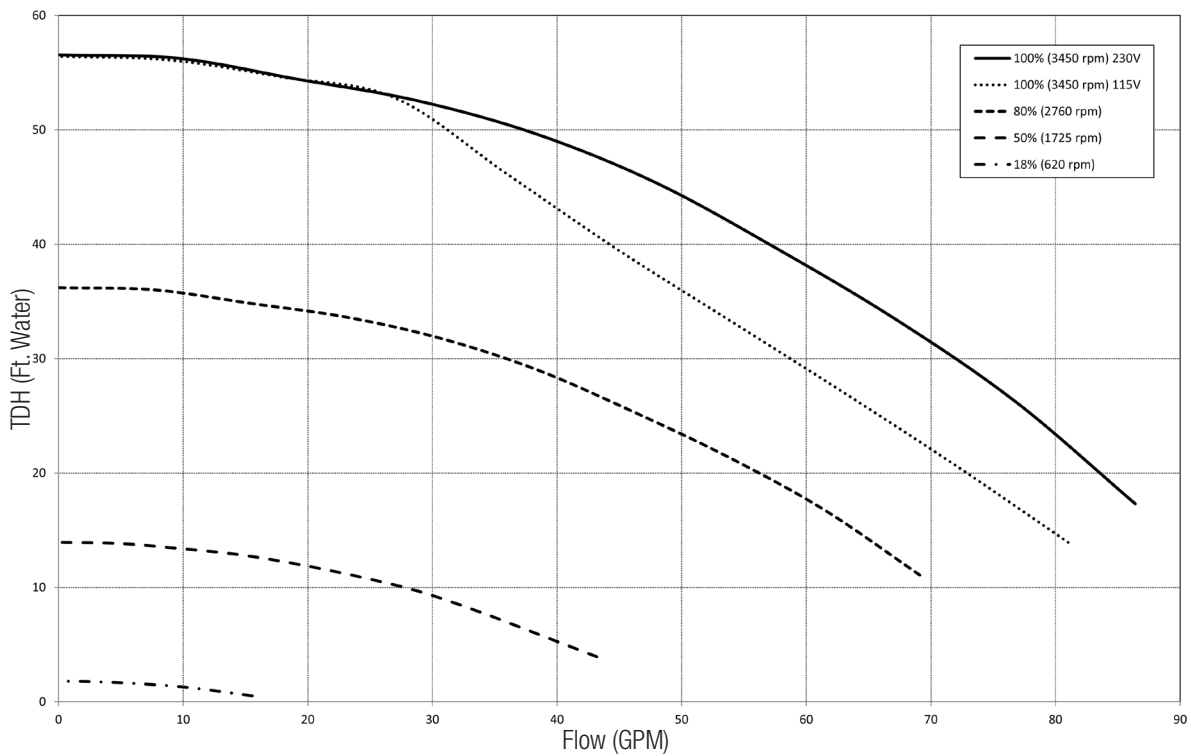



Super Pump VS
Pump Dimensions

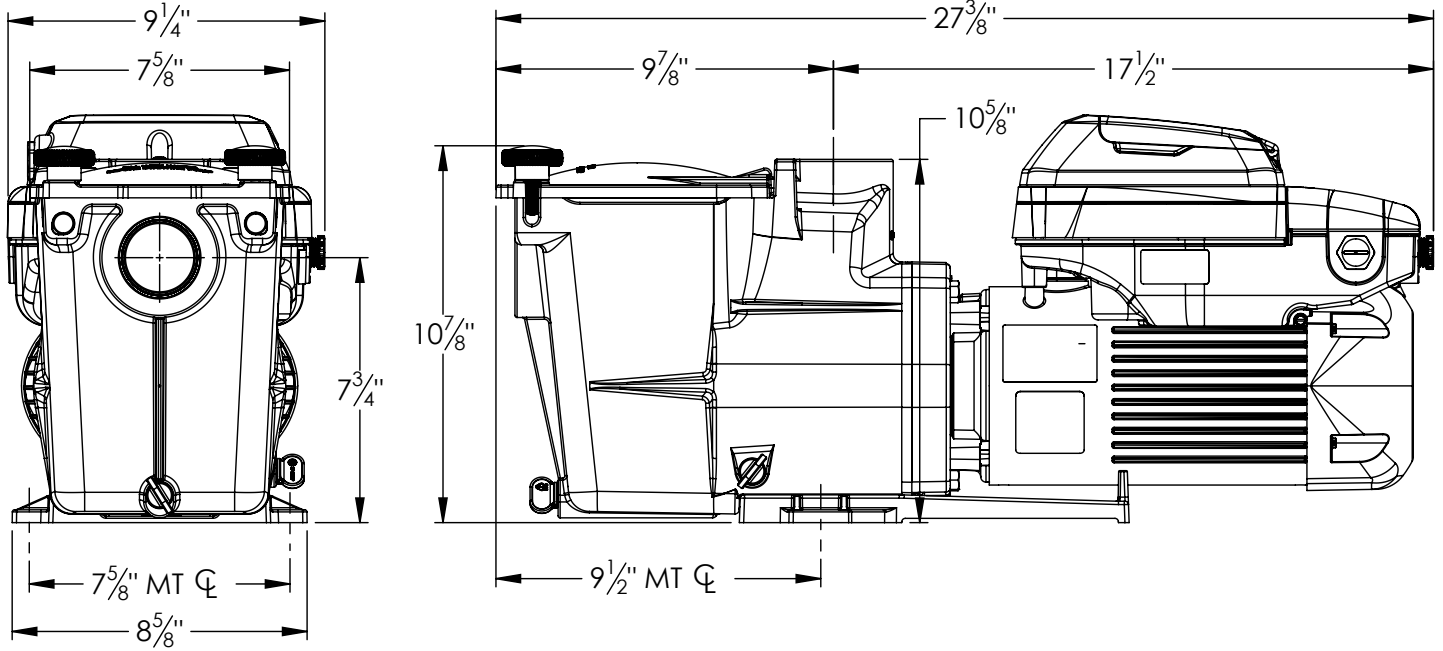

Pump Performance Curve

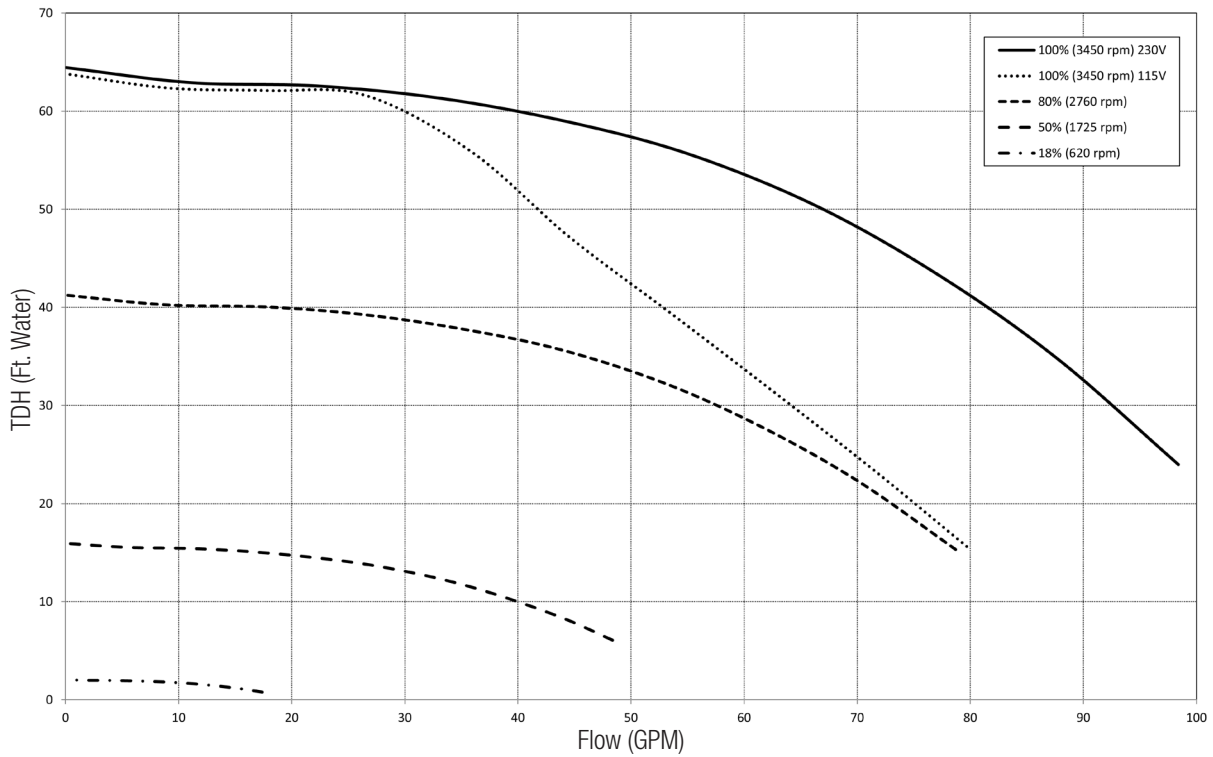



TriStar VS 1.85
Pump Dimensions

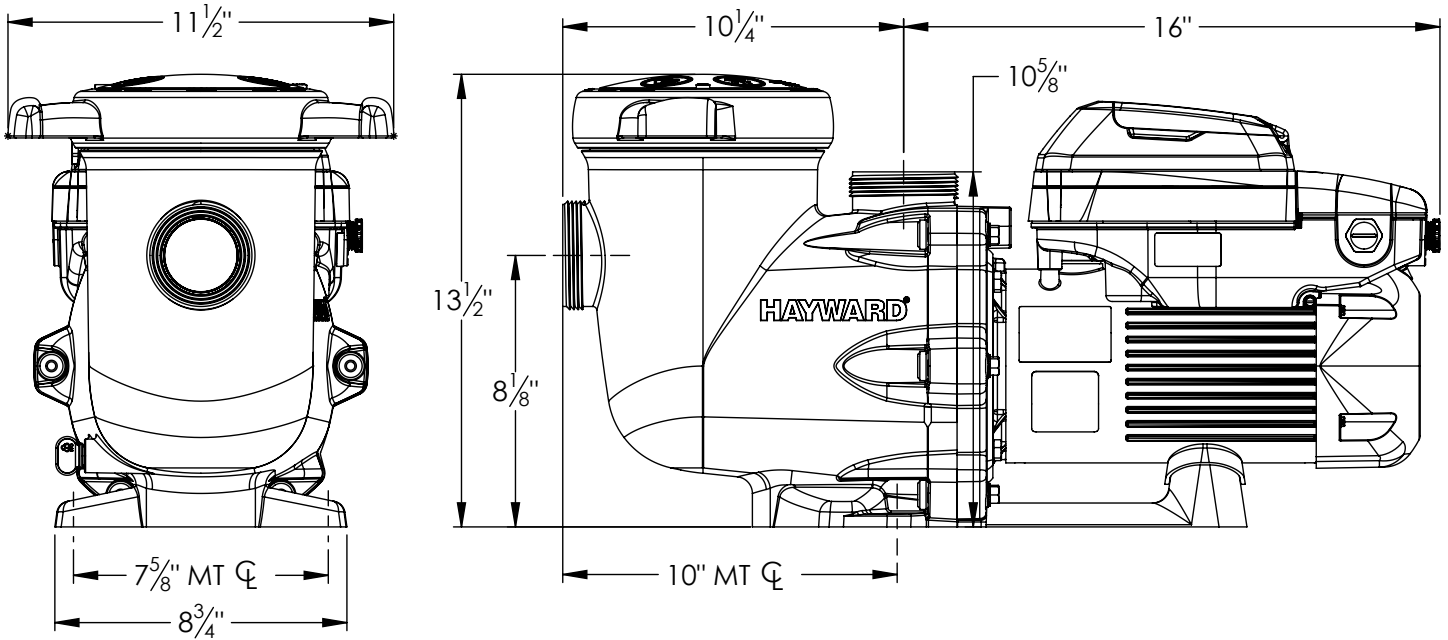

Pump Performance Curve

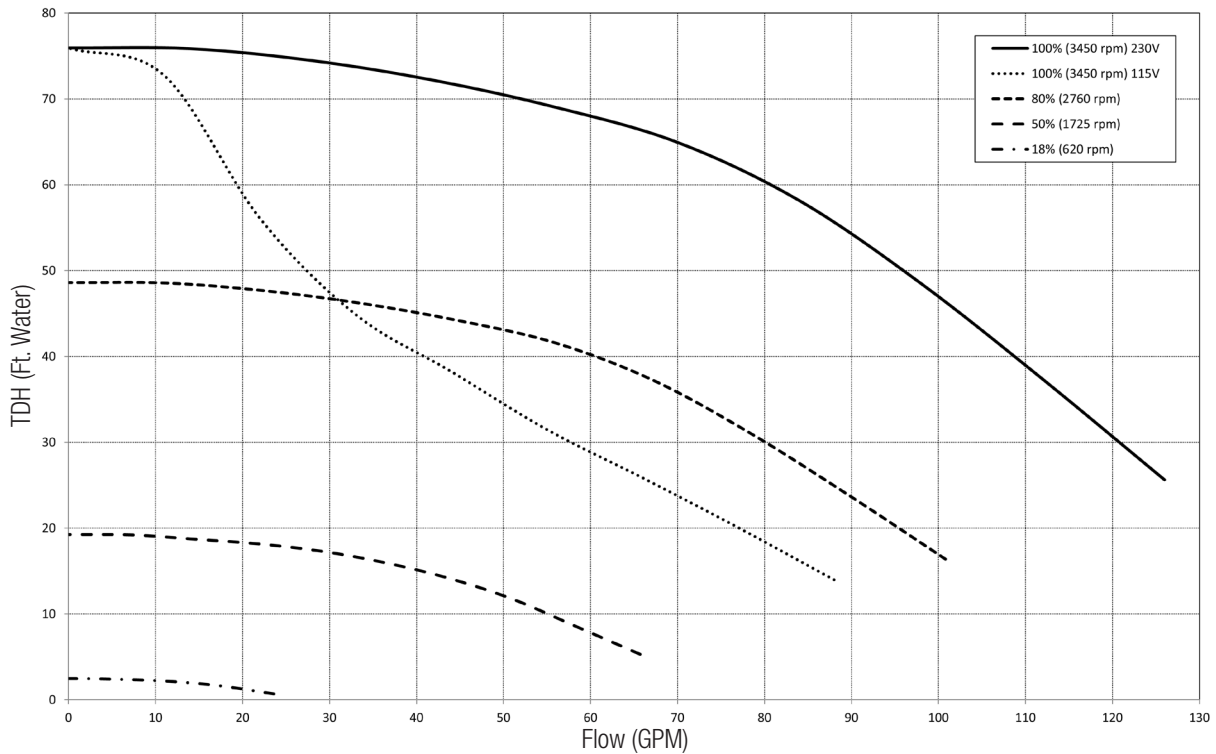



TriStar VS 2.70
Pump Dimensions

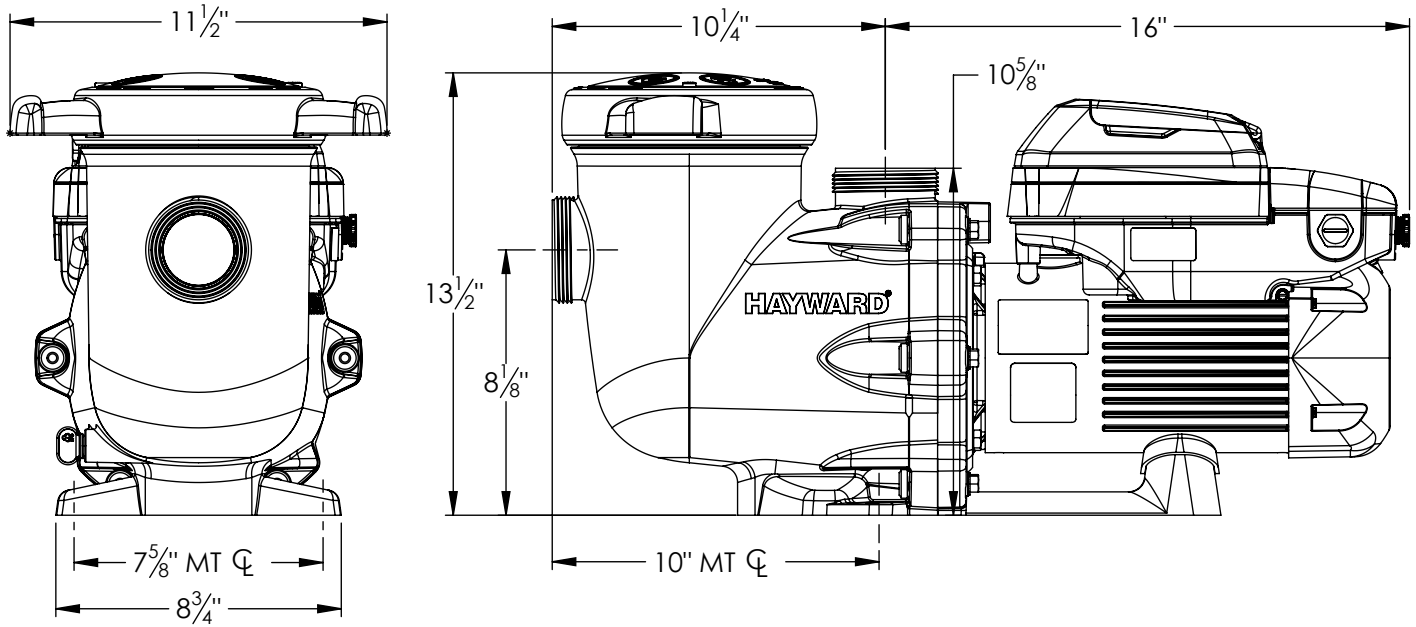

Pump Performance Curve

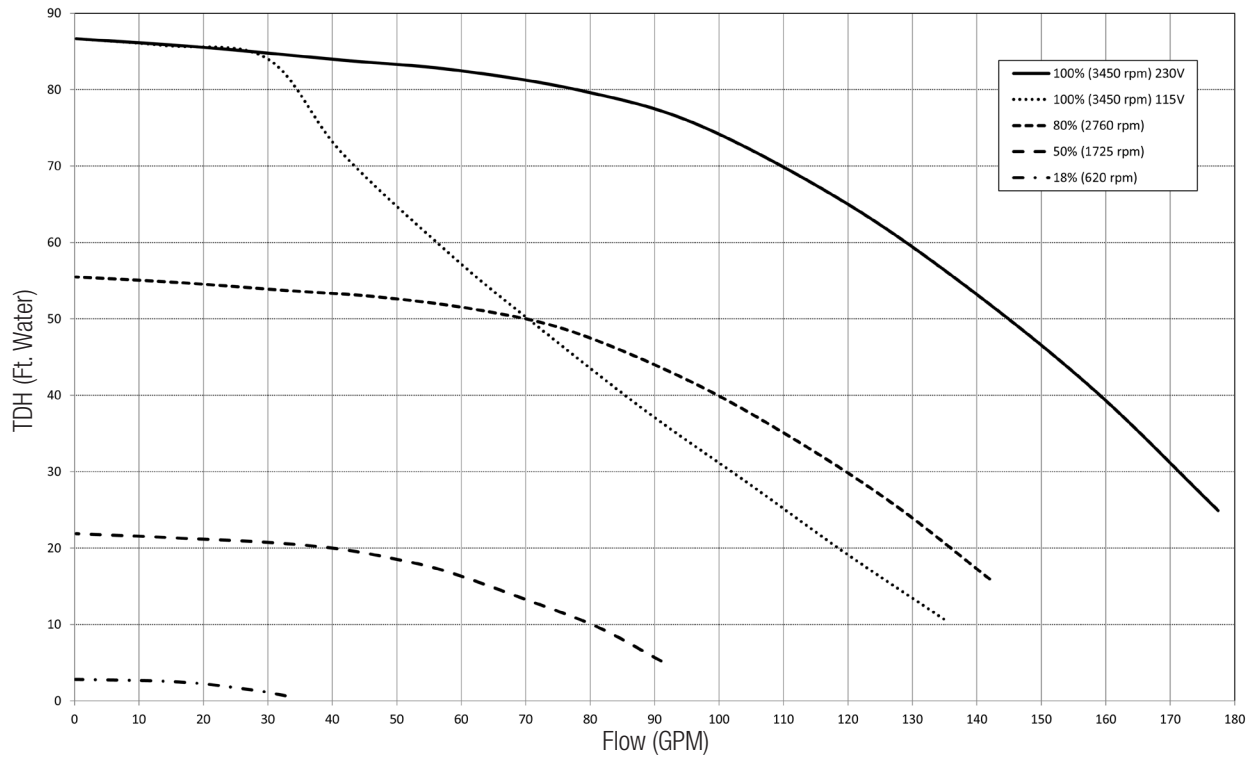



TriStar XL VS
Pump Dimensions

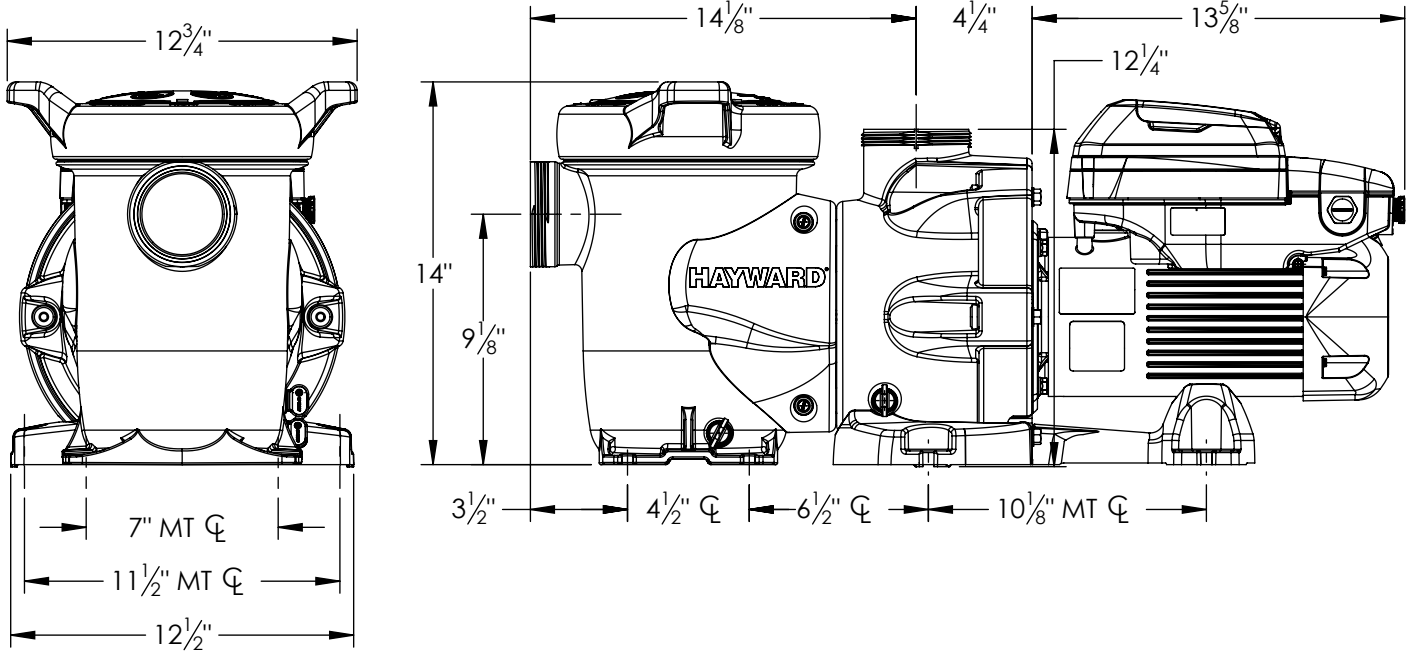

Pump Performance Curve

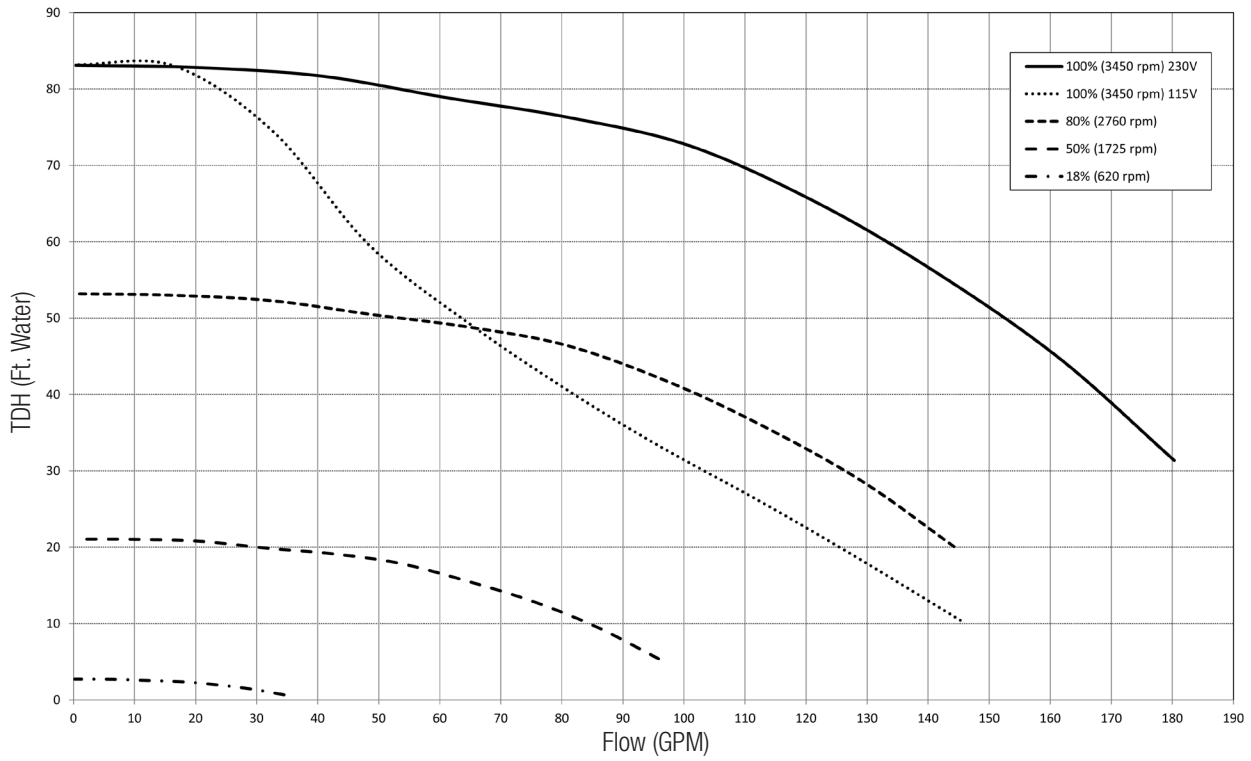

Installation

⚠ WARNING – This product should be installed and serviced only by a qualified professional.

Product Overview

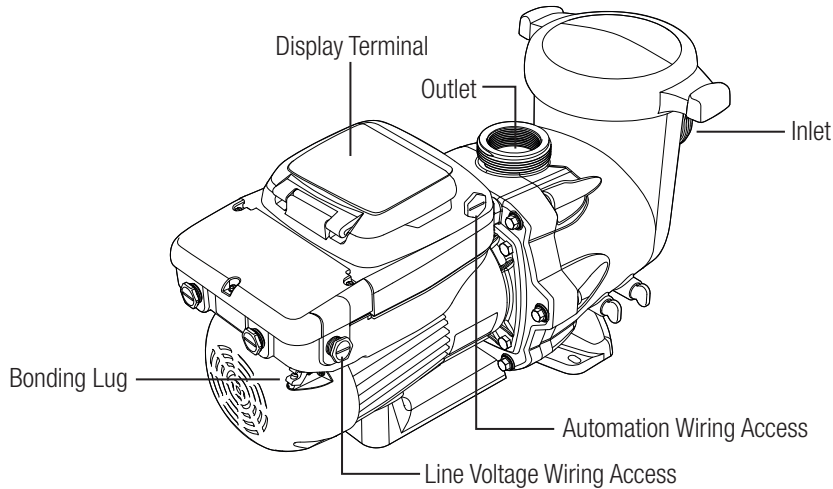

Choosing A Pump Location

Place the pump as close to the pool as practical. Run suction lines as directly as possible to reduce friction loss. Suction lines should have a continuous upward slope starting from the lowest point in the line. Joints must be tight but not overtightened. The suction line diameter must be equal to or larger than the discharge line diameter. Though the pump is designed for outdoor use, it is advised to place pump and filter in the shade to shield them from continuous direct heat. Select a well-drained area that will not flood when it rains. Do NOT install the pump and filter in a damp or non-ventilated location. Keep the motor clean. Pump motors require free circulation of air for cooling.

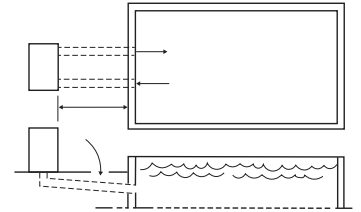

Mounting the Pump

The base of the pump must be level, rigid, and vibration free. Install the pump on a level concrete slab or other rigid base to meet all local and national codes. Secure the pump to the base with screws or bolts to reduce vibration and stress on the pipe or hose joints.

The pump mount must:

- Allow the pump inlet height to be as close to water level as possible.
- Allow use of short, direct suction pipe to reduce friction losses.
- Allow for valves in suction and discharge piping.
- Be protected from excess moisture and flooding.
- Allow adequate access for servicing the pump and piping.

MAXIMUM RECOMMENDED SYSTEM FLOW RATE BY PIPE SIZE

Pipe Size in. [mm]	Maximum Flow Rate GPM [LPM]	Minimum Straight Pipe Length "L" in. [mm]*
1-½" [50]	45 [170]	7-½" [190]
2" [63]	80 [300]	10" [254]
2-½" [75]	110 [415]	12-½" [317]
3" [90]	160 [600]	15" [381]

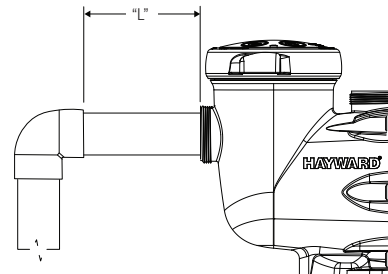

NOTE: It is recommended to use a minimum length of straight piping (shown as "L" in above diagram), equivalent to 5 pipe-sized diameters, between the pump suction inlet and any plumbing fittings such as elbows or valves.

When installing the pump, ensure the proper pipe and equipment sizing can handle the required maximum flow. It is recommended to set the maximum speed in order to not exceed the maximum flow rate.



HAYWARD®

⚠ WARNING – Hazardous Pressure. Pumps, filters, and other equipment/components of a swimming pool filtration system operate under pressure. Filtration equipment and/or components that are incorrectly installed and/or improperly tested may fail, resulting in severe personal injury or death.

Plumbing the Pump

Use PTFE tape to seal the threaded connections on the molded plastic components. All plastic fittings must be new or thoroughly cleaned before use. When applying PTFE tape to plastic threads, wrap the entire threaded portion of the male fitting with 1-2 layers of tape. With the open end of the fitting facing you, start at the end of the fitting and wind the tape clockwise.

NOTE: Do NOT use Plumber's Pipe Dope as it may cause plastic components to crack.

NOTE: The pump suction and outlet ports have molded-in thread stops. Do NOT attempt to force the hose connector fitting past this stop. It is only necessary to tighten fittings enough to prevent leakage. Tighten fitting by hand, then use a tool to engage fitting an additional 1-½ turns. Use care when using PTFE tape as friction is reduced considerably; do NOT overtighten fitting or you may cause damage. If leaks occur: remove the connector, clean off the old PTFE tape, rewrap with 1-2 additional layers of PTFE tape, and reinstall the connector.

NOTE: Fittings (elbows, tees, valves, etc.) restrict flow. For better efficiency, use the fewest possible fittings. Avoid fittings that could cause an air trap. Pool and spa fittings MUST conform to the International Association of Plumbing and Mechanical Officials (IAPMO) standards.

Connecting the Electrical Components

⚠ WARNING – All electrical wiring MUST conform to local codes, regulations, and the National Electric Code (NEC).

⚠ WARNING – Ground and bond the pump before connecting to electrical power supply. Failure to ground and bond the pump can cause serious or fatal electrical shock hazard. Do NOT ground to a gas supply line. To avoid dangerous or fatal electrical shock, turn OFF power to pump before working on electrical connections. **Fire Hazard:** Match the supply voltage to pump nameplate voltage. Ensure that the electrical supply available agrees with the pump's voltage, phase, and cycle, and that the wire size is adequate for the amps rating and distance from the power source. Use copper conductors only.

Electrical Specs

Refer to motor nameplate or table on page 12 for voltage, current, and branch circuit ratings. Use copper conductors only. For indoor and outdoor use. Connect pump to the specified branch circuit for 230 VAC or 115 VAC in accordance with local codes, regulations, and the National Electric Code (NEC). A disconnecting means located at least 5 ft. from the inside wall of the pool, spa, or hot tub must be provided.

Voltage

The pump voltage MUST NOT exceed 10% above or below nameplate rated voltage. Higher voltage may cause components to overheat, causing overload tripping and reduced component life. If voltage is less than 90% or more than 110% of rated voltage when pump is running at full load, consult the power company.

Grounding and Bonding

1. Install, ground, bond, and wire the pump in accordance with local or national electrical code requirements.
2. Permanently ground the pump. Use the green ground terminal provided under the access plate. Use the size and type of wire required by code. Connect the ground terminal to electrical service ground.
3. Bond the pump to the pool structure. Bonding connects all metal parts within and around the pool with a continuous wire. Bonding reduces the risk of a current passing between bonded metal objects, which could potentially cause electrical shock if grounded or shorted. Reference NEC codes for all wiring standards including, but not limited to, grounding, bonding and general wiring procedures.
4. Use a solid copper conductor size 8 or larger. Run wire from the external bonding lug to the reinforcing rod or mesh. Connect a No. 8 AWG (8.4 mm²) [No. 6 AWG (13.3 mm²) for Canada] solid copper bonding wire to the pressure wire connector (provided on the motor housing), to all metal parts of swimming pool, spa, or hot tub, then to all electrical equipment, metal piping (except gas piping), and conduit within 5 ft. (1.5 m) of inside walls of swimming pool, spa, or hot tub.

Wiring

⚠ WARNING – All electrical wiring MUST conform to local codes, regulations, and National Electric Code (NEC)

1. The pump MUST be permanently connected to a circuit. If there are other lights or appliances on the same circuit, be sure to add their amp loads before calculating wire and circuit breaker sizes. Use the circuit breaker as the master On-Off switch.
2. If this VS pump is replacing an existing pump controlled by a separate mechanical time clock, connect the VS pump directly to the line power supply and bypass the time clock. You can then use the time clock to power other equipment (such as a heater, heat pump, or booster pump) that require filter pump operation. To operate the other equipment in this manner, set the timer on the time clock to power the equipment during a cycle when the VS pump runs at an appropriate flow rate, as defined by the timer set in the Timer menu.

Installing the Line Voltage

Please review the sections above before continuing with the installation procedure.

1. TURN OFF THE ELECTRICAL POWER AT THE CIRCUIT BREAKER.
2. Remove the three (3) screws securing the wiring compartment cover. Remove the cover to access the drive wiring compartment.

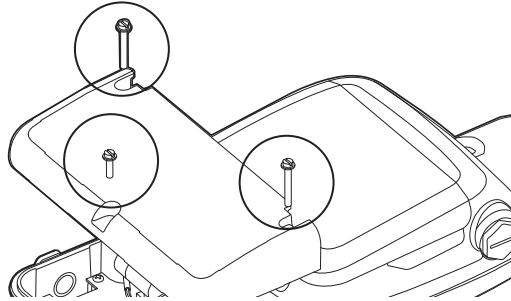

3. Connect the line power supply wiring to the terminals as shown in the diagram below. Wiring must be routed through one of the right-hand side conduit openings using a liquid-tight cord grip appropriately sized for the cable.

NOTICE - Route the wiring directly from the field conduit to the terminal block as shown. Do not bundle excess wiring inside the drive enclosure.

- Use copper conductors only.
- Acceptable for field wiring.
- Not suitable for use with rigid metal conduit.
- **REMOVE TEST LEADS PRIOR TO INSTALLATION.**

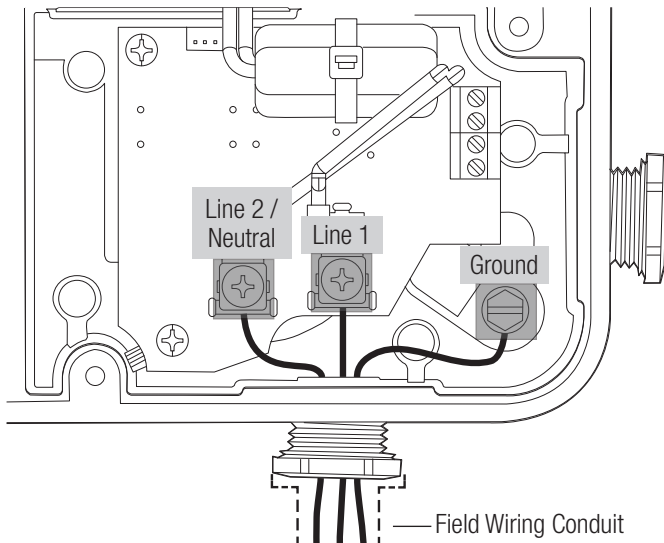

Pump Family	Voltage	Current Rating	Branch Circuit
MaxFlo VS Super Pump VS	230 VAC	6.5 amps	15 amps
	115 VAC	7.2 amps	
TriStar VS 1.85	230 VAC	7.4 amps	
	115 VAC	7.2 amps	
TriStar VS 2.70 TriStar XL VS	230 VAC	10.2 amps	20 amps
	115 VAC	12.2 amps	

4. After making all electrical connections: replace the wiring compartment cover, ensure it is properly aligned with the motor drive, and tighten the three (3) screws to secure. This cover is essential for protecting internal electronics.
5. Connect the pump to the pool bonding system with a 8 AWG (6 AWG for Canada) wire using the bonding lug on the outside of the drive enclosure as shown below.

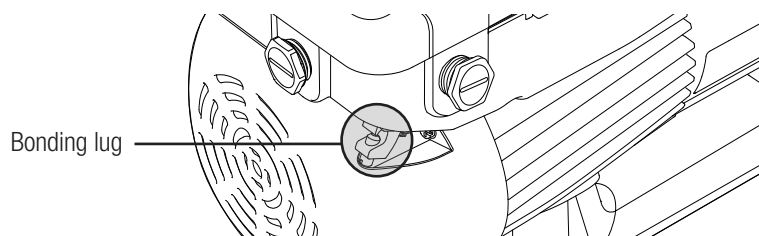



HAYWARD®

Operation

Prior to Start-Up

It may be necessary to perform a water pressure test prior to initial use to ensure the plumbing system is functioning properly. Use the following criteria to complete this test:

- Have a professional perform this test.
- Ensure all Hayward pump and system components are removed from system prior to performing test.

⚠ WARNING – If circulation equipment must remain in the plumbing system during water pressure test, do not apply more than 10 psi pressure to the system. Be sure water pressure has been released, using the filter manual air relief valve, before removing pump strainer cover.

⚠ WARNING – All suction and discharge valves **MUST** be OPEN, as well as the filter air relief valve (if available) on the filter, when starting the circulating pump system. Failure to do so could result in severe personal injury.

Starting and Priming the Pump

Instructions to start the pump for the first time varies between operation methods (Standalone, OmniX, or Remote Control). Read through the following pages to determine how to start the pump.

Before You Begin

Fill the strainer housing with water to suction pipe level. If water leakage occurs from anywhere on the pump or filter, DO NOT start the pump. If no leakage occurs, stand at least 10 ft from pump and/or filter and proceed with starting the pump.

⚠ WARNING – Return to the filter to close the filter manual air relief valve when a steady stream of water (not air or air and water) is discharged from valve. Failure to do so could result in severe personal injury.

⚠ CAUTION – NEVER OPERATE THE PUMP WITHOUT WATER. Water acts as a coolant and lubricant for the mechanical shaft seal. NEVER run pump dry. Running pump dry may damage seals, causing leakage, flooding, and voids warranty. Fill strainer housing with water before starting motor.

⚠ CAUTION – Do NOT add chemicals to pool/spa system directly in front of pump suction. Adding undiluted chemicals may damage pump and voids warranty.

⚠ NOTICE – Before removing strainer cover:

1. STOP PUMP before proceeding.
2. CLOSE VALVES in suction and outlet pipes.
3. RELEASE ALL PRESSURE from pump and piping system using filter manual air relief valve. See filter owner's manual for more details.
4. Remove strainer cover and fill strainer housing with water.
5. Clean and lubricate strainer cover O-Ring with "Jack's 327" if necessary.
6. Replace strainer cover on strainer housing.
7. OPEN VALVES in suction and outlet pipes.

NOTE: Tighten strainer cover lock ring or hand knobs by hand only (no wrenches).

Turn on power and wait for pump to prime, which can take up to fifteen (15) minutes. Priming time will depend on vertical length of suction lift and horizontal length of suction pipe. If pump does NOT prime within 15 minutes, stop the motor and determine the cause. Be sure all suction and discharge valves are open when the pump is running. See Troubleshooting section for more details.

Display User Interface Overview

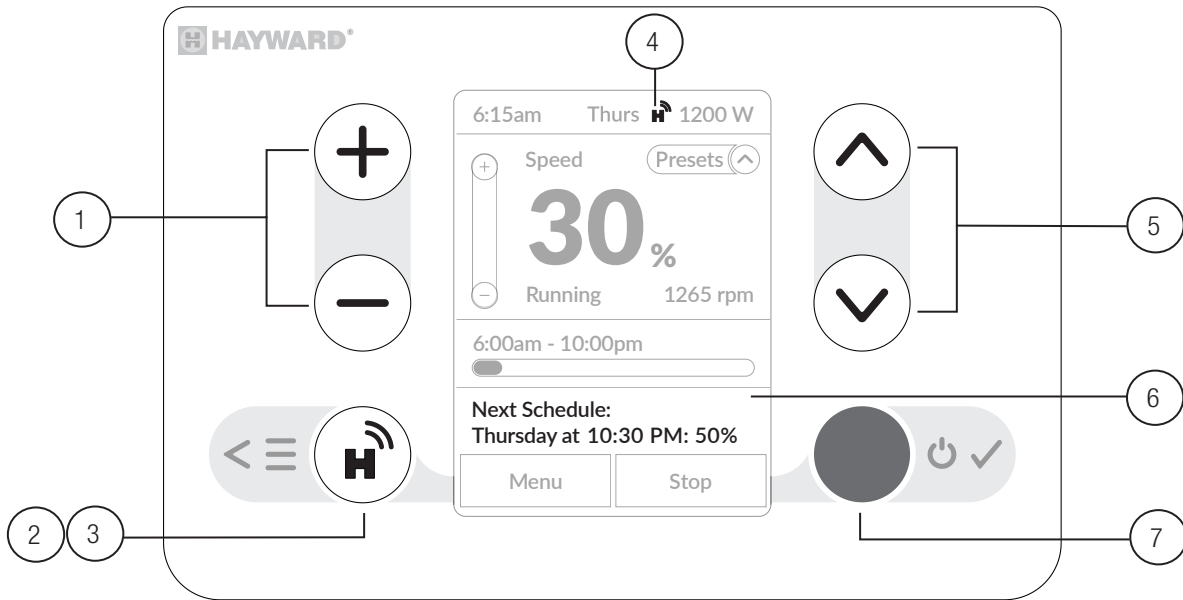

- Change Speed:** Press “+” or “-” buttons to increase or decrease pump speed.
- Menu and Back:** Press the “H” button to access the menu options (See “Standalone Operation”) and to return to previous dialog screen.
- OmniX Claiming:** Press the “H” button to claim pump with OmniX (See “OmniX Operation”).
- Configured through OmniX:** Icon displays when connected to the OmniX app (See “OmniX Operation”).
- Navigation and Presets:** Press the “Up” or “Down” buttons to navigate menu options. Press Up or Down from the Home screen to open the Presets menu.
- Status Messages:** Any status messages will display here.
- Select and Start/Stop Pump:** Press the “Select” button to select menu options, enter dialog screens, and start/stop pump operation.

⚠ WARNING – Pressing the “Select” button disables pump operation. The pump will NOT resume scheduled operation or freeze protection until restarted.

NOTICE – Keep display lid closed when not in use.

Standalone Operation

Use the display terminal to operate your pump with or without OmniX or Remote Control connections.

Press the “H” button on the display to enter the Menu panel.

- **Presets:** Create, modify, and start preset modes.
- **Schedules:** Create, manage, and edit schedules.
- **Settings:** Access General, Display, and Control settings.
- **Equipment Info:** View Firmware, Hayward Unique Address, and display info.
- **Diagnostics:** Access Error log, Events log, and Pump status.
- **Legal Info:** View legal info, including FCC and IC Regulatory information.

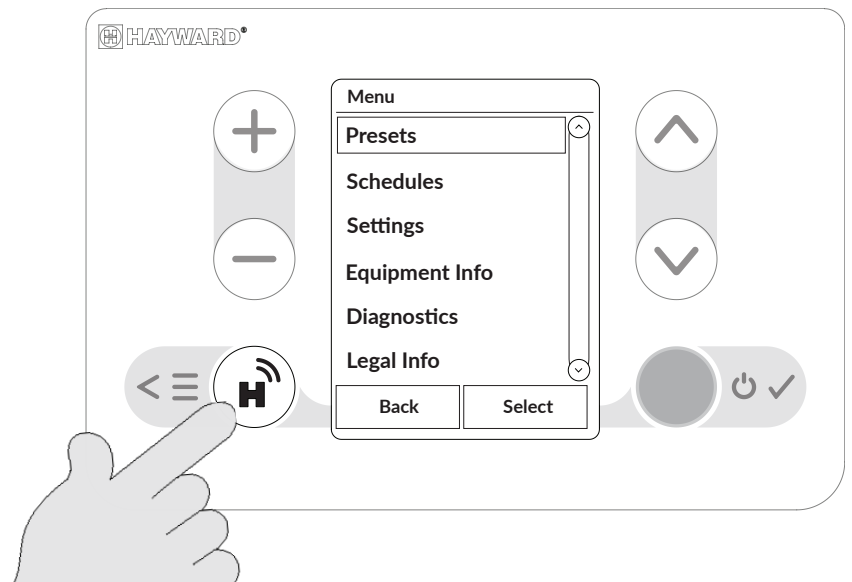



OmniX Operation

The OmniX app allows you to control your pump from the convenience of a mobile device. With the addition of a Hayward OmniX Gateway, OmniX equipment can be controlled beyond Bluetooth® range and away from home.

Scan the QR Code below to download the OmniX App



Claiming Pump with Bluetooth® Pairing

1. Scan the QR code and download the OmniX app from your mobile app store.
2. Enable Bluetooth on your mobile device.
3. Create or log in to an account in the OmniX app. You may use an existing Hayward OmniLogic account.
4. Apply power to the pump and press the “H” button on the display once. The display will show the “H” icon in gray, indicating that the pump is ready to be claimed.
NOTE: When power is first applied to the pump, the pump will turn on for priming. To override priming, press the “Select” button.
5. Create a new site or connect to an existing OmniX site by following the instructions in the OmniX app.
6. Claim and configure the pump by following the instructions on the OmniX app. Once claimed, the “H” icon on the display screen will become solid black.

OmniX Gateway Connection

Once you claim the pump, you can configure and control it using the OmniX app within the typical Bluetooth range of your mobile device. To control the pump remotely through the web, you must purchase the Hayward OmniX Gateway (W3GATEWAYX1) and add it to your home’s network. Once added, the Gateway will act as a bridge between your mobile device and all Hayward internet-enabled equipment within your home network.

Control Equipment from the OmniX App

Note that the OmniX app will have the same function capabilities whether you are connected via Bluetooth or through the web using a Hayward Gateway. Refer to the following information when using the app:

Home Page

- 1 **OmniX Gateway** - If a Hayward OmniX Gateway (W3GATEWAYX1) is installed, this tile will provide access to Gateway settings. The OmniX Gateway provides internet connectivity for remote app control of OmniX Equipment.
- 2 **Body of Water** - Access settings for the Body of Water.
- 3 **Control Tiles** - Access Equipment page (See next page).
- 4 **Home** - Shortcut to Home page.
- 5 **Schedules** - Shortcut to Schedules page.
- 6 **Messages** - Shortcut to Messages (Alerts and Notifications).
- 7 **Menu** - Access to:
 - Site Settings
 - Select Site
 - Create Site
 - Service Mode
 - About
 - Help
 - Account
 - Logout

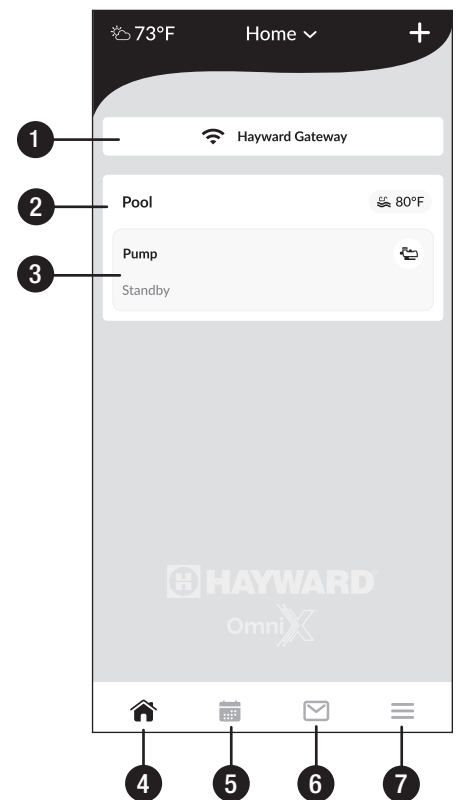

Equipment Page

- 1 **Status** - View operating state.
- 2 **Pump Speeds** - Select a preset speed (Low, Medium or High).
- 3 **Speed Slider** - Adjust speed with custom speed control slider.
- 4 **Settings** - View Pump Diagnostics, History and Configuration (See below).
- 5 **Countdown Timer** - Set custom countdown timers.
- 6 **Schedules** - Create, delete and modify schedules.
- 7 **Equipment Toggle** - Enable/disable pump operation.
- 8 **Network** - View method and quality of equipment network.
- 9 **Schedule Toggle** - Enable/disable schedules.

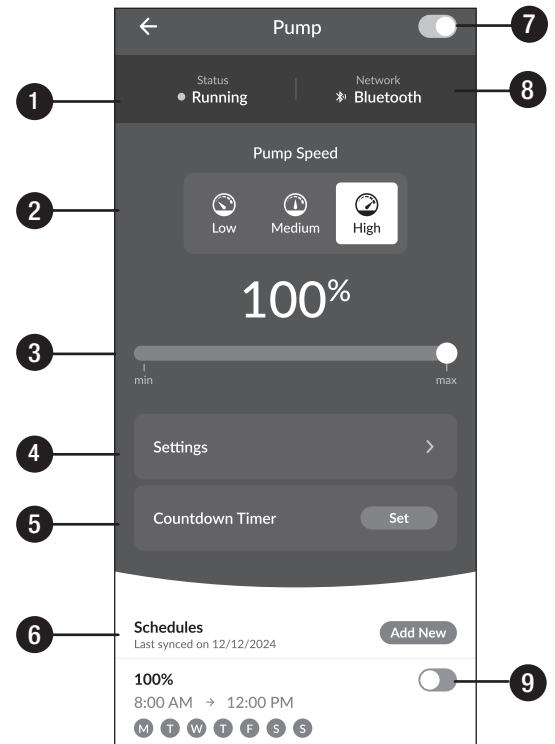

Settings Page

- 1 **Equipment Info** - View detailed pump information.
- 2 **Diagnostics** - View pump operating parameters.
- 3 **History** - View past diagnostic information.
- 4 **Configuration** - Modify pump configuration settings (See next page).
- 5 **Delete Equipment** - Remove piece of equipment from the OmniX app. The equipment must be reset and reclaimed to regain control through the OmniX app. See instructions for resetting and claiming the device.

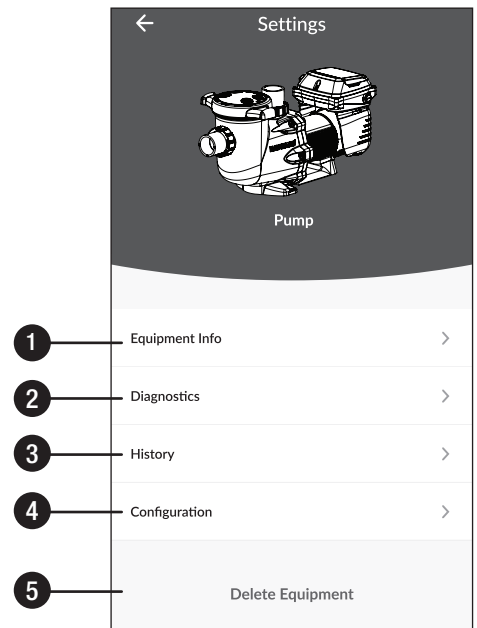

Configuration Page

- 1 **Pump Name** - Edit pump name.
- 2 **Pump Type** - Change pump type (Filter, Water Feature, Booster).
- 3 **Min/Max Speed** - Edit minimum and maximum speed range.
- 4 **Speed Presets** - Edit Low, Medium, and High preset speeds.
- 5 **Priming** - Enable/disable priming.
- 6 **Freeze Protect** - Enable/disable freeze protect.
- 7 **Sensor Calibration** - Adjust temperature reading for sensor calibration.
- 8 **Temperature Sensor** - Add air or water temperature sensor.

← Configuration	
BASIC SETTINGS	
1	Pump Name Pump ✎
2	Pump Type Filter Pump ✎
SPEED	
3	Min/Max Speed 18% / 100% ✎
4	Speed Presets 25% / 50% / 100% ✎
PRIMING	
5	Priming Disabled ✎
FREEZE PROTECT	
6	Freeze Protect Enabled, 38°F, 50% ✎
TEMPERATURE SENSOR	
7	Sensor Calibration 0°F ✎
8	Temperature Sensor Air / Outdoor ✎

Remote Control Operation

This pump is designed to operate with Hayward, Jandy®, and Pentair® remote controllers. Refer to the “Display and Automation” section of this manual for compatibility, wiring, and configuration details.

Display and Automation

Changing the Display Terminal Orientation on Pump

You can rotate the display terminal to one of four positions. After installation, loosen the two screws securing the display terminal to the motor drive, lift the display, rotate it to the desired position, and tighten the two screws in the new position.

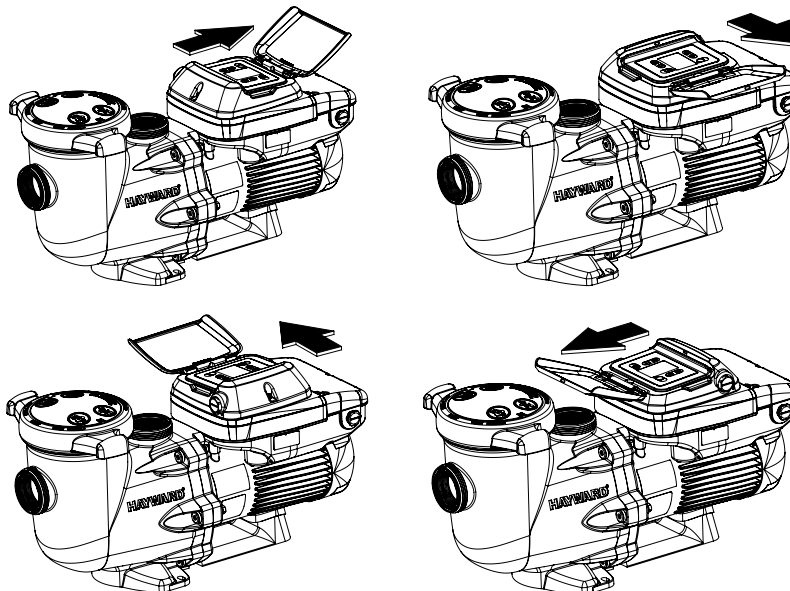

Display Wiring Overview

Remove the two screws attaching the display to the pump and lift to access the wiring underneath the panel to make wall mounting and automation connections.

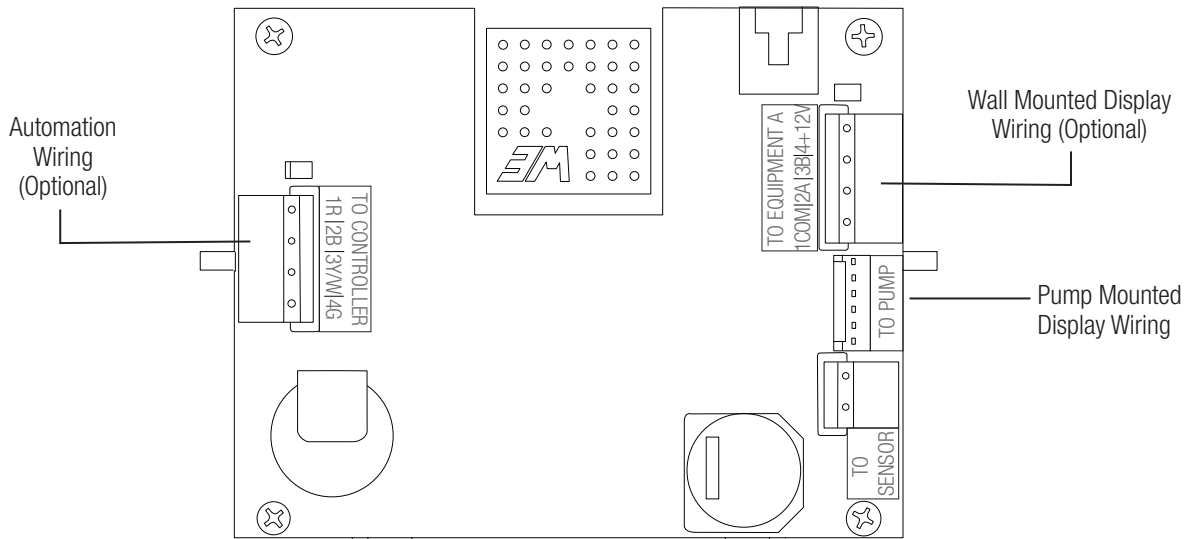

Wall Mounting the Display (Optional)

The display can be mounted on a wall or flat surface using the optional Remote Mounted Display Kit (SPX3400DRKIT). Remote mounting requires a length of 4 conductor cable not provided.

1. TURN OFF THE ELECTRICAL POWER AT THE CIRCUIT BREAKER.
2. Loosen the two screws securing the display terminal to the motor drive and remove the display terminal (See Figure A).

Figure A

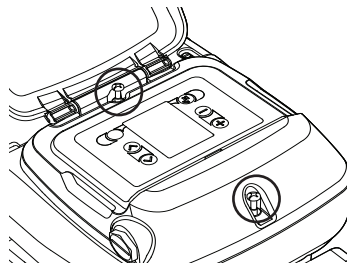

3. Remove the connector from the "To Pump" terminal on the display to disconnect the short cable coming from the motor drive. This cable is not used when wall mounting the display (See Figure B).

Figure B

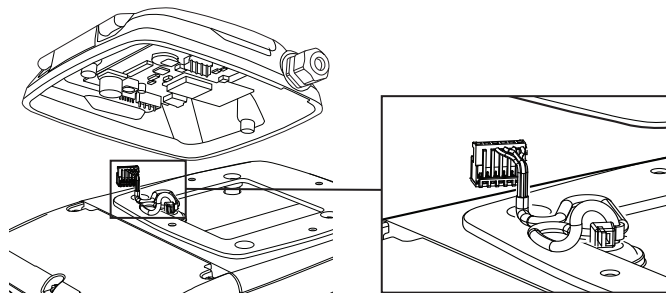

Internal cable with connector removed from display

- Remove the three (3) screws securing the wiring compartment cover to the motor drive. Remove the cover to access the drive wiring compartment (See Figure C).

Figure C

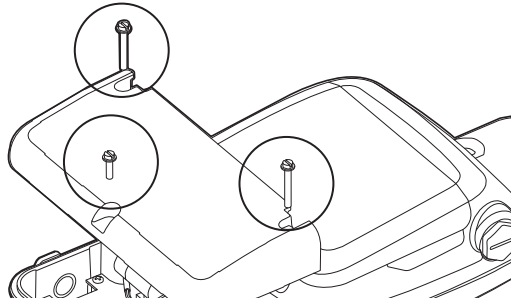

- Loosen the connector screws on the RS485 terminal block on the pump motor and remove the wires (See Figure D). Cover the ends of the wires with electrical tape. This cable is not used.

Figure D

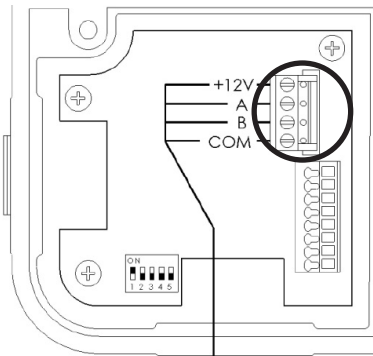

- Mount the wall mount plate provided in the Remote Mounted Display Kit in the desired location.
- Route the new display cable (not included) through the slot on the bottom of the wall mount plate (See Figure E).

Figure E

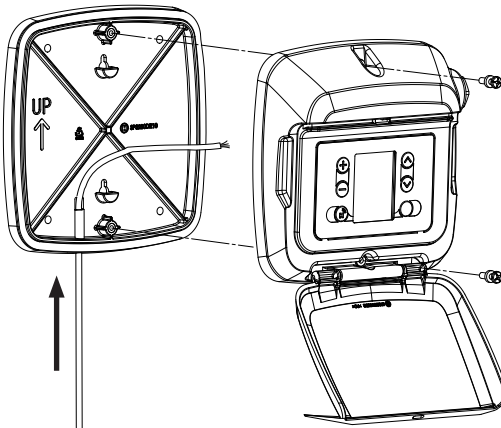

- Wire the cable to the RS485 terminal block labeled "To Equipment A" located on the display PCB. (See Figure F).

Figure F

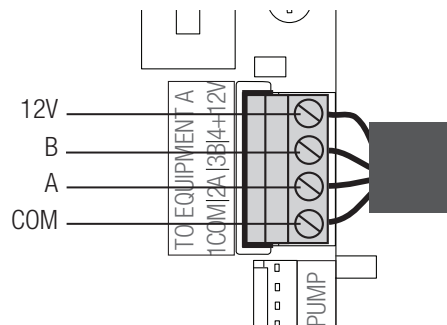

9. Mount the display to the wall mount plate using the two screws (See Figure E).
10. Remove the hex plug and route the cable through one of the left-hand side conduit openings on the motor drive using a liquid-tight cord grip appropriately sized for the cable. Connect the display cable to the RS485 terminal on the motor drive (See Figure G).

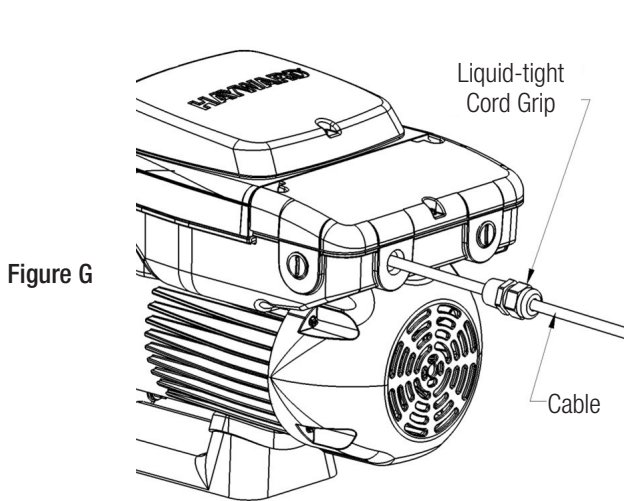
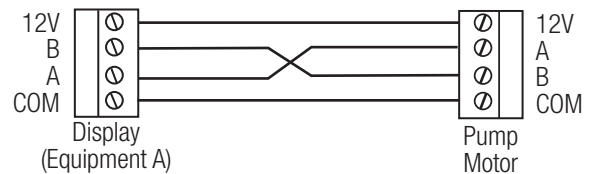
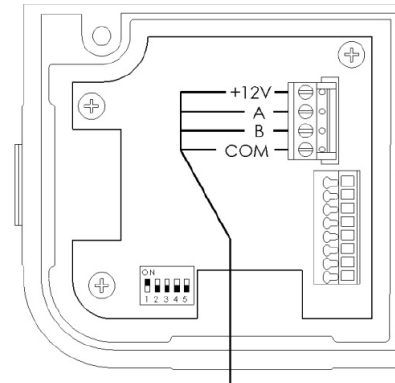

Figure G



11. Reinstall the wiring compartment cover, ensuring it is properly aligned with the motor drive, and tighten the three (3) screws to secure.
12. Install the blank cover provided in the Remote Mounted Display Kit on the motor drive in the desired orientation. This cover is essential for protecting internal electronics (See Figure H).
13. Apply power to the system and resume normal operation.

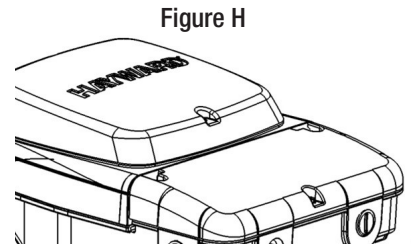

Figure H

Connecting an Automation Controller (Optional)

Compatibility

This pump can communicate with and be controlled by the following Hayward, Jandy, and Pentair pool controls and firmware.

Hayward	
Automation	Required Firmware
OmniLogic® OmniPL® OmniHub® S3 Omni®	R.1.0.0 or later
ProLogic®	ProLogic 3.00 or later
AquaLogic®	AquaLogic 2.65 or later AquaPlus 2.65 or later
E-Command®	E-Command 4 2.8.0 or later
OnCommand®	OnCommand 1.00 or later

Jandy and Pentair
Update to the latest firmware version.

Wiring at the Pump

1. TURN OFF THE ELECTRICAL POWER AT THE CIRCUIT BREAKER.
2. Loosen the two screws securing the display terminal to the motor drive and remove the display terminal.

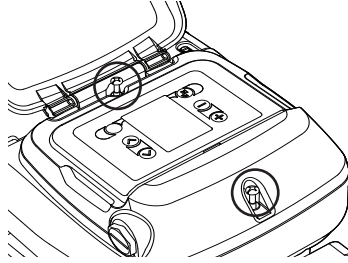

3. Locate the cable and weatherproof fitting included in the Communication Cable Kit supplied with your pump. Remove the hex plug in the display port and install the included fitting to secure. Run one end of the cable through the fitting as shown below. Tighten the fitting after wiring is complete.
NOTE: Do not disconnect the cable labeled "To Pump". Confirm the first dip switch is set to ON.

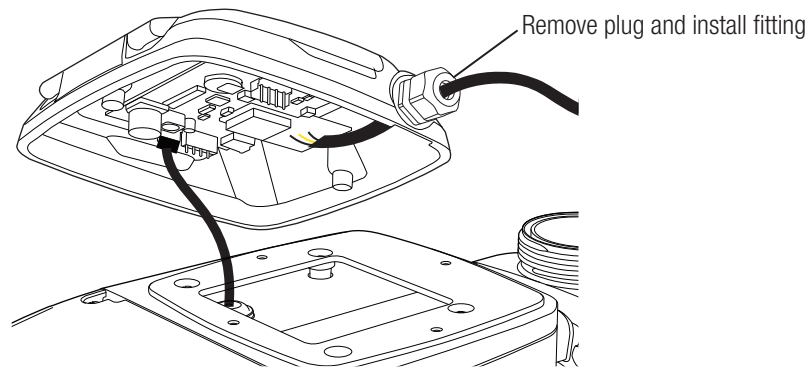

4. Locate the unused screw terminal block on the "To Controller" pins. Use this connector when wiring to your pool's automation control.

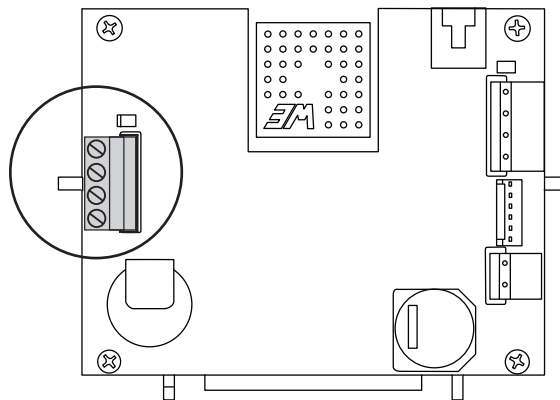



Hayward Controller Wiring and Configuration

Wiring at Hayward Controller

Most Hayward controls only require a two-wire connection from the control's low-speed bus terminal block to the pump's automation control terminal block, however some controls require a third wire connection. Refer to the installation manual for your Hayward control system to determine which terminals to use. You can also refer to the numbers printed next to the terminal block on the control circuit board.

1. Connect the cable as shown below. For all controls: Wire "2" to "2" and "3" to "3". Some controls require a bare wire connection from "4" to "4". Terminal "1" is not used. Refer to your pool control's installation manual for information on how to connect and configure your pump.
2. Reinstall the display terminal onto the motor drive using the existing two screws.

NOTE: If a longer run is required, the connection wire must be rated for a minimum of 300 V and may be up to 200 ft in length.

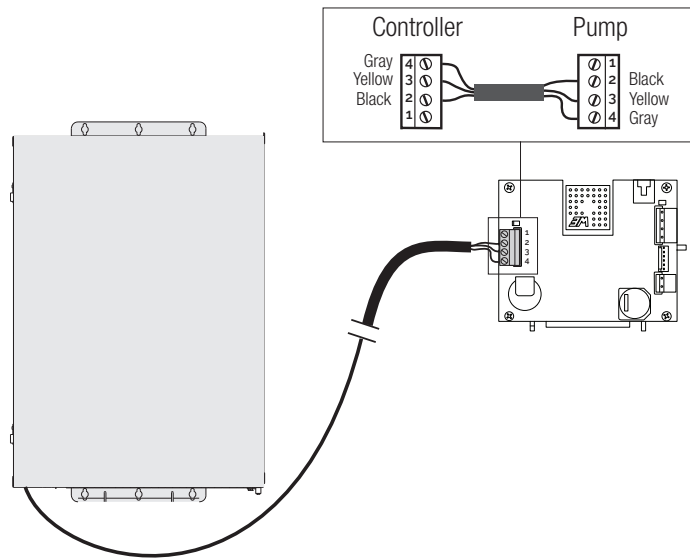

Configuring Hayward Omni

The pump's Hayward Unique Address (HUA) shows on the display home screen when connected to a Hayward automation pool controller. Use the HUA to identify the pump during Omni configuration. Refer to the Configuration section of your Omni control manual for more details, which can be found at www.hayward.com.

Hayward Unique Address (HUA)

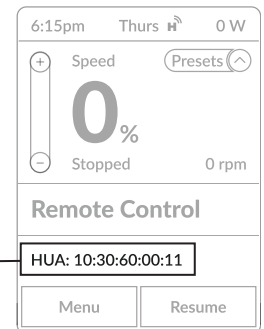

Configuring Hayward ProLogic, AquaLogic, OnCommand and E-Command

Set your device address by using the display to navigate to the ProLogic menu:

Menu > Settings > Remote Control > Hayward > Set Device Address > ProLogic

Each pump connected to the control must be set to a different address. Refer to your control manual for additional details, which can be found at www.hayward.com.

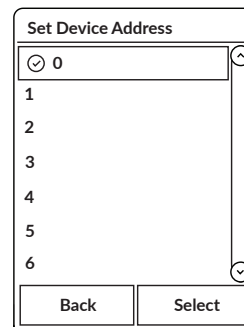

Device Address set at Pump	Corresponding Output at Control
0	Pool Filter
1	Aux 1/Spa Filter
2	Aux 2
3	Aux 3
4	Aux 4
5	Aux 5
6	Aux 6
7	Aux 7
8	Aux 8
9	Aux 9
10	Aux 10
11	Aux 11
12	Aux 12
13	Aux 13
14	Aux 14
15	Light Button



Jandy® Controller Wiring and Configuration

Wiring at Jandy Controller

Use a 3-wire connection to connect a Hayward pump to a Jandy controller. Refer to your Jandy controller manual for additional wiring information.

1. Connect the cable according to the table below.

Description	Pump	Jandy Control
	Pin 1 Do Not Use	Pin 1 Do Not Use
+ Data	Pin 2 Black	Pin 2 Black
- Data	Pin 3 Yellow	Pin 3 Yellow
Ground	Pin 4 Green	Pin 4 Green

2. Confirm the first dip switch on the pump is set to ON.
3. Reinstall the display terminal onto the motor drive using the existing two screws.

Configuring a Jandy Controller

1. On the pump display terminal:
 - a. Ensure your pump is updated to the latest firmware by selecting **Menu > Equipment Info** on the display terminal.
 - b. Return to the Menu screen by pressing the “H” button and select **Settings > Remote Control > Jandy**. The display enters the Jandy submenu where you can set the pump address and adjust timeout period.
 - c. Set the pump address by selecting **Address** and choosing an unused address number. Press the “Select” button to confirm.
2. In the Jandy iAquaLink app:
 - a. Tap the gear icon in the top right corner.
 - b. Select **System Setup > VS Pump Setup**.
 - c. Under “Legacy Jandy,” select the DIP Switch address that corresponds to the address set on the display terminal in Step 1c. For proper operation, do not set to any other pump type.
 - d. Under “Application,” select either **Filter** or **Aux Pump** depending on how the pump will be used. For proper operation, do not set to any other pump type.
 - e. Configure Feature Speeds as desired.
 - f. Configure Master Speeds to the following settings:

Min Speed	600 RPM. DO NOT SET LOWER THAN 600 RPM.
Max Speed	3450 RPM. DO NOT SET HIGHER THAN 3450 RPM.
Priming Speed	3450 RPM (default).
Priming Duration	1 minute (Adjust to fit the needs of your system).
Freeze Protect Speed	2500 RPM (Adjust to fit the needs of your system).

Pentair® Controller Wiring and Configuration

Wiring at Pentair Controller

Use a 3-wire connection to connect a Hayward pump to a Pentair controller. Refer to your Pentair controller manual for additional wiring information.

1. Connect the cable according to the table below.

Description	Pump	Pentair Control
	Pin 1 Do Not Use	Pin 4 Do Not Use
+ Data	Pin 2 Black	Pin 3 Yellow
- Data	Pin 3 Yellow	Pin 2 Green
Ground	Pin 4 Green	Pin 1 Black

2. Confirm the first dip switch on the pump is set to ON.
3. Reinstall the display terminal onto the motor drive using the existing two screws.

Configuring a Pentair Controller

1. On the pump display terminal:
 - a. Ensure your pump is updated to the latest firmware by selecting **Menu > Equipment Info** on the display terminal.
 - b. Return to the Menu screen by pressing the “H” button and select **Settings > Remote Control > Pentair**. The display enters the Pentair submenu where you can set the pump address and adjust timeout period.
 - c. Set the pump address by selecting **Address** and choosing an unused address number. Press the “Select” button to confirm.
2. Configure the pump with the following settings at your Pentair controller, referring to the controller manual as needed:

Pump Type	Pentair IntelliFlo® VS or Pentair VS. For proper operation, do not set to any other pump type.
Pump Name	Add a descriptive name for your pump.
Pump Address	Match the address set on the display terminal in Step 1c.
Min Speed	600 RPM. DO NOT SET LOWER THAN 600 RPM.
Max Speed	3450 RPM. DO NOT SET HIGHER THAN 3450 RPM.
Step Size	50 RPM or 100 RPM.
Priming Speed	3450 RPM (default).
Max Prime Time	Set to fit the needs of your system.



Maintenance

NOTICE – NEVER add chlorine tablets to the strainer basket.

- Clean strainer basket regularly. Do NOT strike basket. Inspect cover gasket regularly and replace as necessary.
- Hayward pumps have self-lubricating motor bearings and shaft seals. No lubrication is necessary.
- Keep motor clean. Keep motor air vents free of obstructions to avoid damage. Do NOT use water to hose off motor.
- Occasionally, shaft seals must be replaced due to wear or damage. Replace with genuine Hayward seal assembly kit (See “Changing the Shaft Seal”).

Storing and Winterizing

⚠ WARNING – Separation Hazard. Do not purge the system with compressed air. Purging the system with compressed air can cause components to explode, with risk of severe injury or death to anyone nearby. Use only a low pressure (below 5 psi), high volume blower when air purging the pump, filter, or piping.

NOTICE – Allowing the pump to freeze with water in it will void the warranty.

⚠ CAUTION – Use ONLY propylene glycol as antifreeze in your pool/spa system. Propylene glycol is nontoxic and will not damage plastic system components; other antifreezes are highly toxic and may damage plastic components in the system.

Drain all water from pump and piping when expecting freezing temperatures or when storing pump for a long time (see instructions below). Gravity drain system as far as possible.

Keep motor dry and covered during storage. To avoid condensation/corrosion problems, do NOT cover or wrap pump with plastic film or bags.

Storing Pump for Winterization

⚠ WARNING – To avoid dangerous or fatal electrical shock hazard, turn OFF power to motor before draining pump. Failure to disconnect power may result in serious personal injury or death.

1. Drain water level below all inlets to the pool.
2. Remove drain plugs and strainer cover from strainer housing (See parts diagram on pages 28-32 for pump component locations).
3. Disconnect pump from mounting pad, wiring (after power has been turned OFF), and piping.
4. Once the pump is fully drained of water, reinstall the strainer cover and drain plugs. Store pump in a dry area.

Changing the Shaft Seal

When servicing electrical equipment, basic safety precautions should always be observed, including the following. Failure to follow instructions may result in injury.

⚠ WARNING – To reduce risk of injury, do not permit children to use this product.

- Disconnect all electrical power service to pump before beginning shaft seal replacement.
- Only qualified personnel should attempt rotary seal replacement. Contact your local authorized Hayward Dealer or service center if you have any questions.
- Refer to pages 28-32 for pump component locations.

Exercise extreme care in handling both the rotating and the stationary sections of the two-part replacement seal. Foreign matter or improper handling will easily scratch the graphite and ceramic sealing surfaces.

Refer to pages 28-32 when following the instructions below.

Removing the Motor Assembly

1. Remove the housing bolts, which hold the motor assembly to the pump/strainer housing, using a ½” wrench or socket (9/16” for Super Pump VS).
2. Slide the motor assembly out of the pump/strainer housing to expose the diffuser.
3. For all models except the Super Pump VS: Remove the diffuser screws and pull the diffuser off the seal plate to expose the impeller.



HAYWARD®

Removing the Impeller

4. To prevent the motor shaft from turning, secure using a 5/16" hex wrench in the socket on the motor shaft.
5. For pumps that include an impeller screw: Remove the impeller screw by rotating clockwise (note that screw has left-hand thread). Remove the impeller by rotating counterclockwise.

Removing the Ceramic Seat

6. Remove the spring seal assembly.
7. Remove the seal plate from the motor using a 9/16" wrench or socket (½" for HCP3020VSP). Remove the four bolts that secure the seal plate to the motor. Super Pump VS models do not require a wrench or socket.
8. Press the ceramic seat with rubber cup out of the seal plate. Use a small screwdriver to tap seal out.

STOP - Clean all recesses and parts to be reassembled. Inspect gaskets and replace if necessary.

Seal Installation

9. Clean and lightly lubricate the motor shaft and seal recesses in the seal plate with a dilute solution of non-granulated liquid-type soap. Gently wipe the polished face of the ceramic seal with a soft cotton cloth. Lubricate the rubber cup on the ceramic seat and press it firmly into the recess of the seal plate, with the polished ceramic surface facing out.
10. Reassemble the motor to the seal plate using the motor bolts. Reattach the motor support to the seal plate if removed previously.
11. Gently wipe the black, polished surface of the spring seal assembly with a soft cotton cloth.
12. Press the spring seal assembly onto the motor shaft (or the impeller shaft for Super Pump VS models), with the black polished surface facing the ceramic seat.

Replacing the Impeller and Diffuser

13. Screw the impeller onto the motor shaft in a clockwise direction, and screw the impeller screw (if included) into the motor shaft in a counterclockwise direction. Tighten snugly by holding motor shaft with wrench as noted in Step 3.
14. If your model has an impeller ring, place the impeller ring back onto the impeller with flange facing towards the diffuser.
15. Place the diffuser over the impeller and onto the seal plate. If your model has diffuser screws, align the pins on the diffuser with the holes on the seal plate and replace the diffuser screws.

Replacing the Motor Assembly

16. Slide the motor assembly, with the diffuser in place, into pump/strainer housing, being careful not to disturb the diffuser gasket/O-Ring.
17. Fasten assembly to pump/strainer housing using the housing bolts. (Be sure housing gasket/O-Ring is in lubricated and in place. Replace if damaged). Tighten bolts alternately and evenly to 185 in-lbs (80 in-lbs for Super Pump VS).



Troubleshooting

General Problems

Motor Will NOT Start:

1. Make sure the terminal board connections agree with the wiring diagram on the pump data plate label.
2. Be sure the pump is wired for the available field supply voltage.
3. Check for and correct any improper or loose wiring connections; open switches or relays; tripped circuit breakers, or blown fuses.
4. Manually check the rotation of the motor shaft for free movement and lack of obstruction. Correct if necessary.
5. For Jandy and Pentair controllers: Ensure Pin 1 of the controller dip switch is set to HIGH.

Motor Shuts OFF:

- Check for low voltage or power drop at the motor (often caused by undersized wiring). Contact a qualified professional to verify the electrical connections.

Motor Hums, But Does NOT Start:

- Impeller jammed with debris. Have a qualified repair professional open the pump and remove the debris.

Pump Won't Prime:

1. Empty pump/strainer housing. Make sure the pump/strainer housing is filled with water and the cover O-Ring is clean. Ensure the O-Ring is properly seated in the cover O-Ring groove. Ensure the O-Ring sealing surface is lubricated with "Jack's 327" and that the strainer cover is locked firmly in position. Lubricant will help to create a tighter seal.
2. Loose connections on the suction side. Tighten the pipe/union connections.
NOTE: Any self-priming pump will not prime if there are suction air leaks. Leaks will result in bubbles emanating from the return fittings on the pool wall.
3. Leaking O-Ring or packing glands on valves. Tighten, repair, or replace the valves.
4. Strainer basket or skimmer basket loaded with debris. Remove the strainer housing cover or the skimmer cover. Clean the basket, and refill the strainer housing with water. Tighten the cover.
5. Suction side clogged. Contact a qualified repair professional. You should have 5" - 6" of vacuum at the strainer cover (your pool dealer can confirm this with a vacuum gauge). You may be able to check by removing the skimmer basket and holding an object over the bottom port with the skimmer full and the pump running. If no suction is felt, check for line blockage.
 - a. If the pump develops a vacuum, check for a blocked suction line or a dirty strainer basket. An air leak in the suction piping may be the cause.
 - b. If the pump does not develop a vacuum and the pump has sufficient "priming water":
 - i. Recheck the strainer housing cover and all threaded connections for suction leaks. Check if all system hose clamps are tight.
 - ii. Check voltage to ensure that the motor is rotating at full RPMs.
 - iii. Open the housing cover and check for clogging or obstruction in suction. Check the impeller for debris.
 - iv. Remove and replace the shaft seal only if it is leaking.

Low Flow – Generally:

1. Clogged or restricted strainer or suction line. Contact a qualified repair professional.
2. Undersized pool piping. Correct the piping size.
3. Plugged or restricted discharge line of filter, valve partially closed (high gauge reading). Sand filters – backwash as per manufacturer's instructions; D.E. filters – backwash as per manufacturer's instructions; Cartridge filters – clean or replace the cartridge.
4. Air leak in suction (bubbles issuing from return fittings). Retighten the suction and discharge connections using PTFE tape. Inspect other plumbing connections, and tighten as required.
5. Plugged, restricted, or damaged impeller. Replace the impeller including a new seal assembly.

Noisy Pump:

1. Air leak in suction piping, cavitations caused by restricted or undersized suction line or leak at any joint, low water level in pool, and unrestricted discharge return lines. Correct the suction condition or throttle return lines, if practical. Holding your hand over the return fitting will sometimes prove this, or by putting in a smaller eyeball fitting.
2. Vibration due to improper mounting, etc. Mount the pump on a level surface and secure the pump to the equipment pad.
3. Foreign matter in the pump housing. Loose stones/debris hitting the impeller could be the cause. Clean the pump housing.
4. Motor bearings noisy from normal wear, rust, overheating, or concentration of chemicals causing seal damage, which will allow chlorinated water to seep into bearings wiping out the grease causing bearing to whine. All seal leaks should be replaced at once.

Interference With Home Automation/Power Line Communication Equipment:

1. Make sure the terminal board connections agree with the wiring diagram on the pump data plate label (See page 12) and/or your controller manual.
2. Check for and correct any improper or loose wiring connections.
3. Install noise filter (from home automation/power line communication equipment vendor) to prevent equipment interference.



Check System Messages

Code	Troubleshooting
Check System DC voltage too high	Indicates that the internal DC bus voltage is too high. Verify that line voltage is within 10% of pump rated voltage at the terminal block.
Check System DC voltage too low	Indicates that the internal DC bus voltage is too low. Verify that line voltage is within 10% of pump rated voltage at the terminal block. Also, verify that power supply connections are properly made at the circuit breaker as well as at the terminal block.
Check System Drive is overheated	Indicates that the internal components of the drive have become overheated. Motor airflow path should be checked for obstructions and cleared if present. Check ambient temperature and verify against motor nameplate (50°C/122°F).
Check System Drive is overloaded	Indicates that motor current is too high. Check impeller, diffuser, shaft seal, and motor for any issues or binding.
Check System Motor has stalled	Indicates that the drive has lost control over motor shaft rotation. Check impeller, diffuser, shaft seal, and motor for any issues or binding.
Check System Motor failed to start	Indicates that the drive was not able to start the motor. Check impeller, diffuser, shaft seal, and motor for any issues or binding.
Check System Motor phase lost	Indicates that one of the motor phases is open and that the motor/drive may need to be replaced. Contact Hayward Technical Service for additional assistance.
Check System Current sensing failed	Indicates an issue with the current sense circuit in the motor/drive. The motor/drive may need to be replaced. Contact Hayward Technical Service for additional assistance.
Check System PFC check failed	Indicates an issue with the power factor correction circuit in the drive. The motor/drive may need to be replaced. Verify that line voltage is within 10% of pump rated voltage at the terminal block. Also, verify that power supply connections are properly made at the circuit breaker as well as at the terminal block. Contact Hayward Technical Service for additional assistance.
Check System Processor check failed	Indicates that there is a problem with the processor in the motor/drive, and that the motor/drive may need to be replaced. Contact Hayward Technical Service for additional assistance.
Check System Microelectronic check failed	Indicates an issue with the microcontroller in the drive. The motor/drive may need to be replaced. Contact Hayward Technical Service for additional assistance.
Check System Memory check failed	Indicates that the drive memory has been damaged or corrupted, and that the motor/drive may need to be replaced. Contact Hayward Technical Service for additional assistance.
Check System Display comm failed	Indicates that display is not receiving communication from the drive. If a new display does not resolve the issue, the motor/drive may need to be replaced. Contact Hayward Technical Service for additional assistance.
Check System Drive comm failed	Indicates that there are communication problems inside the motor/drive, and that the motor/drive may need to be replaced. Contact Hayward Technical Service for additional assistance.
Check System Error code XX	Indicates that the display terminal is receiving an error from the motor/drive that it does not understand. Contact Hayward Technical Service for additional assistance.

NOTE: All errors can be manually reset by selecting Stop/Resume when the error message is shown, or by cycling power applied to the pump after the error has occurred. The error log can be cleared by pressing and holding the “-” button while viewing the error log screen. If the troubleshooting steps listed above do not help to resolve the error condition, then the problem may be internal to the motor/drive. Contact Hayward Technical Service at (908) 355-7995 for additional assistance.

Replacement Parts

MaxFlo VS

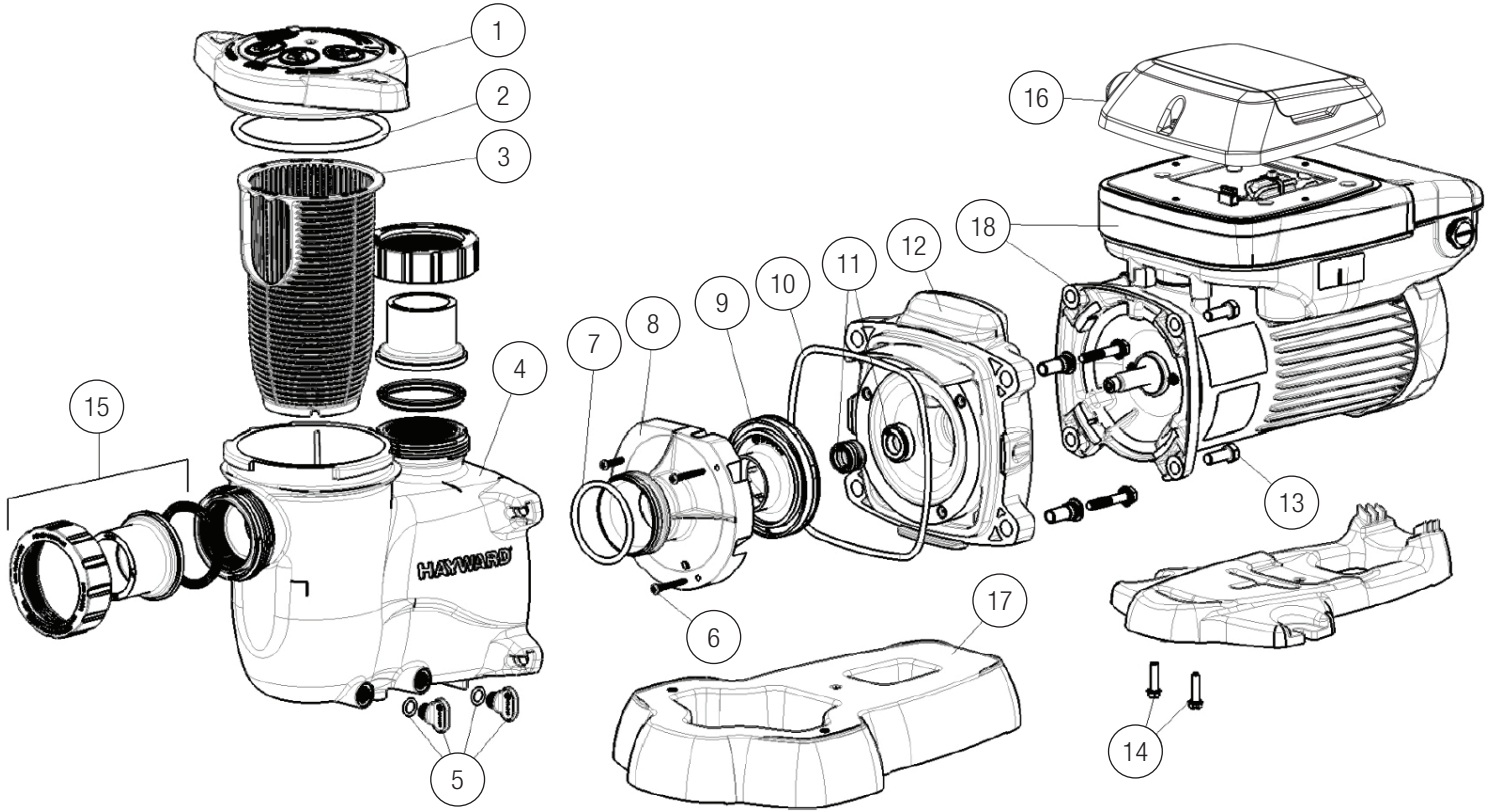

No.	Part Number	Description	Qty.	No.	Part Number	Description	Qty.
1	SPX2300DLS	Strainer Cover Kit (Includes Strainer Cover, Lock-Ring and O-Ring)	1	11	SPX2700SAV	Shaft Seal Assembly (Viton)	1
2	SPX2300Z4	Strainer Cover O-Ring	1	12	SPX2300E	Seal Plate	1
3	SPX2300M	Strainer Basket	1	13	SPX3200Z5PAK4	Motor Bolt (4 Pack)	1
4	SPX2300AA	Pump Strainer Housing with Drain Plugs	1	14	SPX1600Z52	Motor Support Base Mount Screws	1
5	SPX4000FG	Drain Plug with O-Ring	2	15	SPX2700UNKIT	Union Connector Kit (Includes 2 Nuts, Connectors and Gaskets)	1
6	SPX3200Z8	Diffuser Screws (5 Pack)	1	16	VSXDISPLAYX1	Display Terminal Assembly	1
7	SX220Z2	Diffuser O-Ring	1	17	SPX2300GR	Optional Riser Base Aligns with Sta-Rite® Dyna-Pro® Pump*	1
8	SPX2300B	Diffuser	1	18	SPX2303Z1VSPE	Power End Assembly (Includes #7-14, Motor and Drive)	1
9	SPX2710CM	Impeller	1	-	SPX3400DRKIT	Remote Mounted Display Kit	1
10	GMX600F	Housing O-Ring	1	-	SPX3200DRCC	Communication Cable Kit	1

*Sta-Rite and Dyna-Pro are registered trademarks of Pentair Aquatic Systems, which are used herein for identification purposes only. This is a retrofit base for existing Sta-Rite and Dyna-Pro pump installations. Pentair Aquatic Systems is not affiliated with Hayward Pool Products.

Super Pump VS

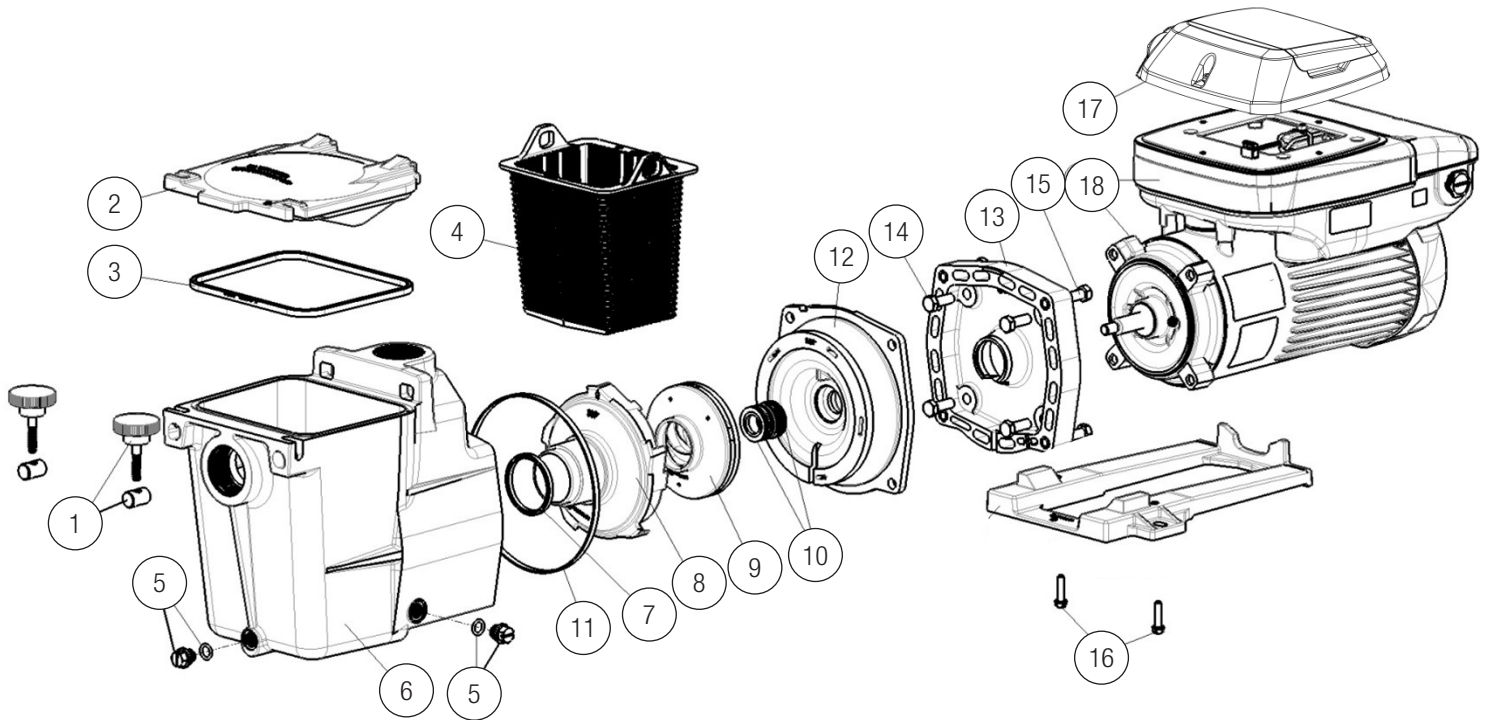

No.	Part Number	Description	Qty.	No.	Part Number	Description	Qty.
1	SPX1600PN	Swivel Nut and Hand Knob	2	11	SPX1600T	Housing Gasket	1
2	SPX1600D	Strainer Cover	1	12	SPX2600E5	Seal Plate	1
3	SPX1600S	Strainer Cover Gasket	1	13	SPX1600F5	Motor Mounting Plate	1
4	SPX1600M	Basket	1	14	SPX0125Z44	Motor Cap Screws (Set of 4)	1
5	SPX4000FG	Drain Plug with Gasket	2	15	SPX1600Z4	Housing Cap Screw	4
6	SPX1620AA	Pump Strainer Housing With Gasket	1	16	SPX1600Z52	Mounting Foot Screws (Set of 2)	1
7	SPX1600R	Diffuser Gasket	1	17	VSXDISPLAYX1	Display Terminal Assembly	1
8	SPX2600B	Diffuser	1	18	SPX2603Z1VSPE	Power End Assembly (Includes #7-14, Motor and Drive)	1
9	SPX2610C	Impeller	1	-	SPX3400DRKIT	Remote Mounted Display Kit	1
10	SPX1600Z2VIT	Shaft Seal Assembly (Viton)	1	-	SPX3200DRCC	Communication Cable Kit	1

TriStar VS 1.85

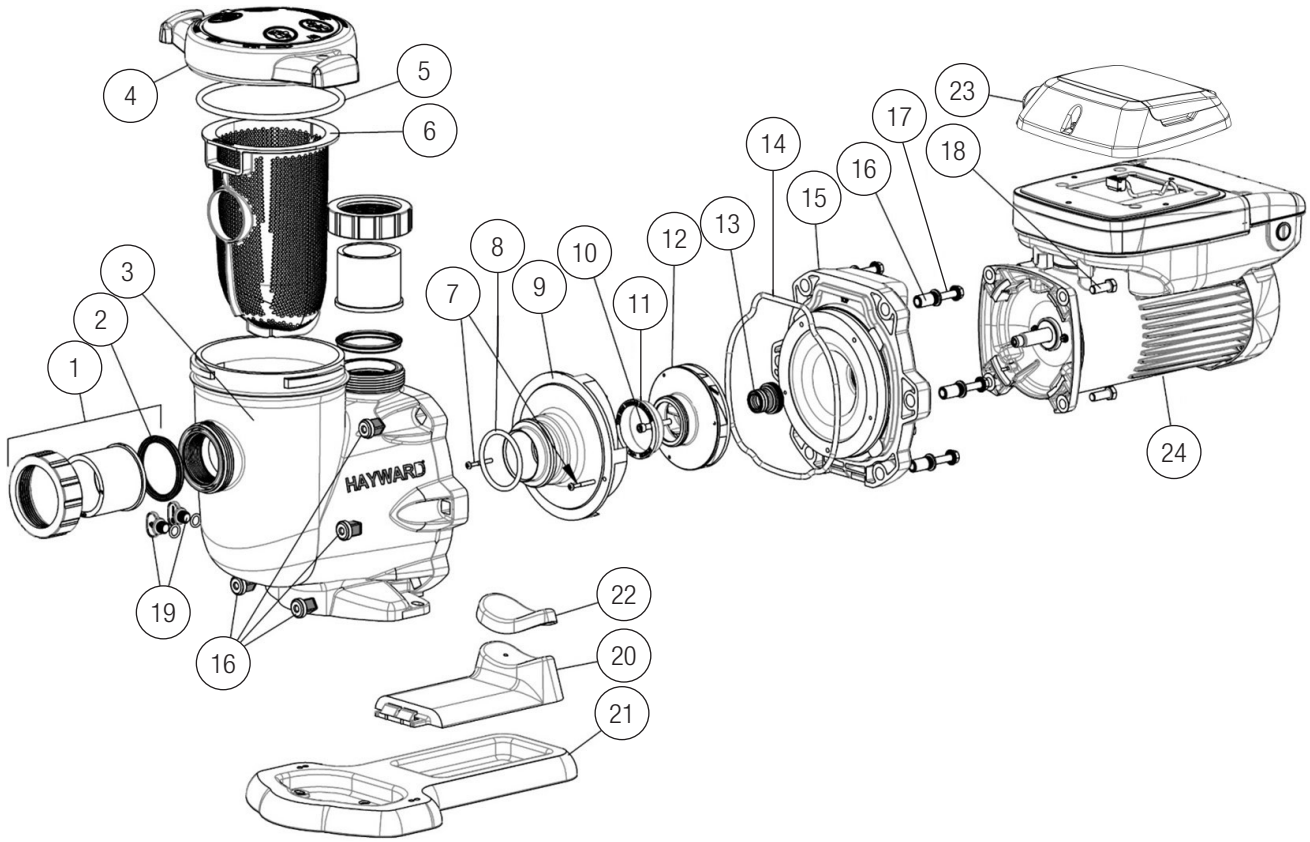

No.	Part Number	Description	Qty.	No.	Part Number	Description	Qty.
1	SPX3200UNKIT	Union Connector Kit (Includes 2 Nuts, Connectors and Gaskets)	1	14	SPX3200T	Housing O-Ring	1
2	SPX3200UG	Union Gasket	1	15	SPX3200E	Seal Plate	1
3	SPX3200A	Pump Strainer Housing, 2" x 2 -/2" with Drain Plugs	1	16	SPX3200Z211	Housing Insert/Seal Plate Spacer Kit	1
4	SPX3200DLS	Strainer Cover Kit (Includes Strainer Cover, Lock Ring and O-Ring)	1	17	SPX3200Z3	Housing Bolt	1
5	SPX3200S	Strainer Cover O-Ring	1	18	SPX3200Z5	Motor Bolt	1
6	SPX3200M	Strainer Basket	1	19	SPX4000FG	Drain Plug with O-Ring	1
7	SPX3200Z8	Diffuser Screw (5 Pack)	1	20	SPX3200GA	Motor Support	1
8	SPX4000Z1	Diffuser O-Ring	1	21	SPX3200WF	Optional Riser Base aligns with Pentair® WhisperFlo® pump*	1
9	SPX3200B3	Diffuser	1	22	SPX3200Q	Motor Support Adapter	1
10	SPX3200Z1	Impeller Screw	1	23	VSDISPLAYX1	Display Terminal Assembly	1
11	SPX3021R	Impeller Ring	1	24	SPX3202Z1VSPE	Power End Assembly (Includes #7-15, 2 ea. #16-17, #18, #24 and Motor Assy)	1
12	SPX3210C	Impeller with Impeller Screw	1	-	SPX3400DRKIT	Remote Mounted Display Kit	1
13	SPX4000SAV	Shaft Seal Assembly (Viton)	1	-	SPX3200DRCC	Communication Cable Kit	1

*WhisperFlo is a registered trademark of Pentair Aquatic Systems, which is used herein for identification purposes only. This is a retrofit base for existing WhisperFlo pump installations. Pentair Aquatic Systems is not affiliated with Hayward Pool Products.

TriStar VS 2.70

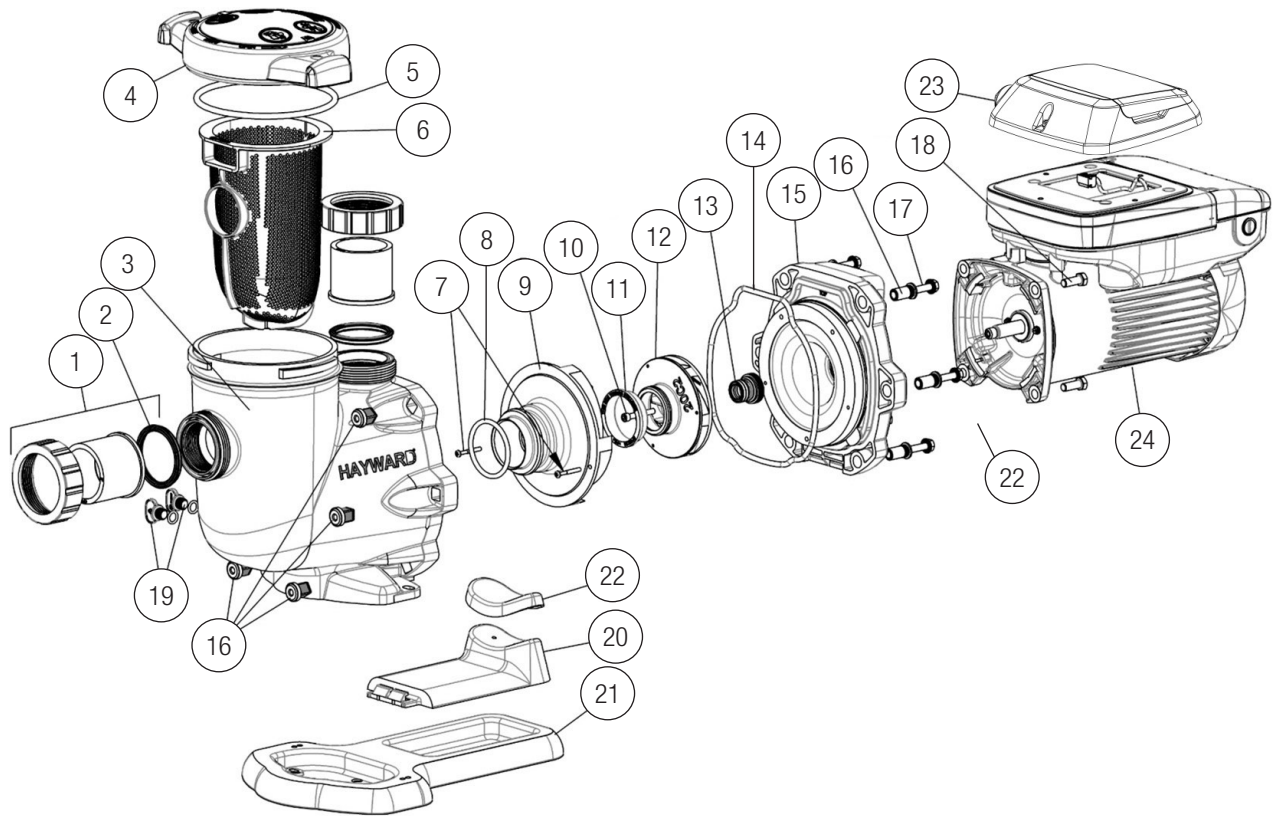

No.	Part Number	Description	Qty.	No.	Part Number	Description	Qty.
1	SPX3200UNKIT	Union Connector Kit (Includes 2 Nuts, Connectors and Gaskets)	1	14	SPX3200T	Housing O-Ring	1
2	SPX3200UG	Union Gasket	1	15	SPX3200E	Seal Plate	1
3	SPX3200A	Pump Strainer Housing, 2" x 2-½" with Drain Plugs	1	16	SPX3200Z211	Housing Insert/Seal Plate Spacer Kit	1
4	SPX3200DLS	Strainer Cover Kit (Includes Strainer Cover, Lock Ring and O-Ring)	1	17	SPX3200Z3	Housing Bolt	1
5	SPX3200S	Strainer Cover O-Ring	1	18	SPX3200Z5	Motor Bolt	1
6	SPX3200M	Strainer Basket	1	19	SPX4000FG	Drain Plug with O-Ring	1
7	SPX3200Z8	Diffuser Screw (5 Pack)	1	20	SPX3200GA	Motor Support	1
8	SPX4000Z1	Diffuser O-Ring	1	21	SPX3200WF	Optional Riser Base aligns with Pentair® WhisperFlo® pump*	1
9	SPX3200B3	Diffuser	1	22	SPX3200Q	Motor Support Adapter	1
10	SPX3200Z1	Impeller Screw	1	23	VSXDISPLAYX1	Display Terminal Assembly	1
11	SPX3021R	Impeller Ring	1	24	SPX3206Z1VSPE	Power End Assembly, Non-SVRS (Includes #7-15, 2 ea. #16-17, #18, #24 and Motor Assembly)	1
12	SPX3220C	Impeller with Impeller Screw	1	-	SPX3400DRKIT	Remote Mounted Display Kit	1
13	SPX4000SAV	Shaft Seal Assembly (Viton)	1	-	SPX3200DRCC	Communication Cable Kit	1

* WhisperFlo is a registered trademark of Pentair Aquatic Systems, which is used herein for identification purposes only. This is a retrofit base for existing WhisperFlo pump installations. Pentair Aquatic Systems is not affiliated with Hayward Pool Products.

TriStar XL VS

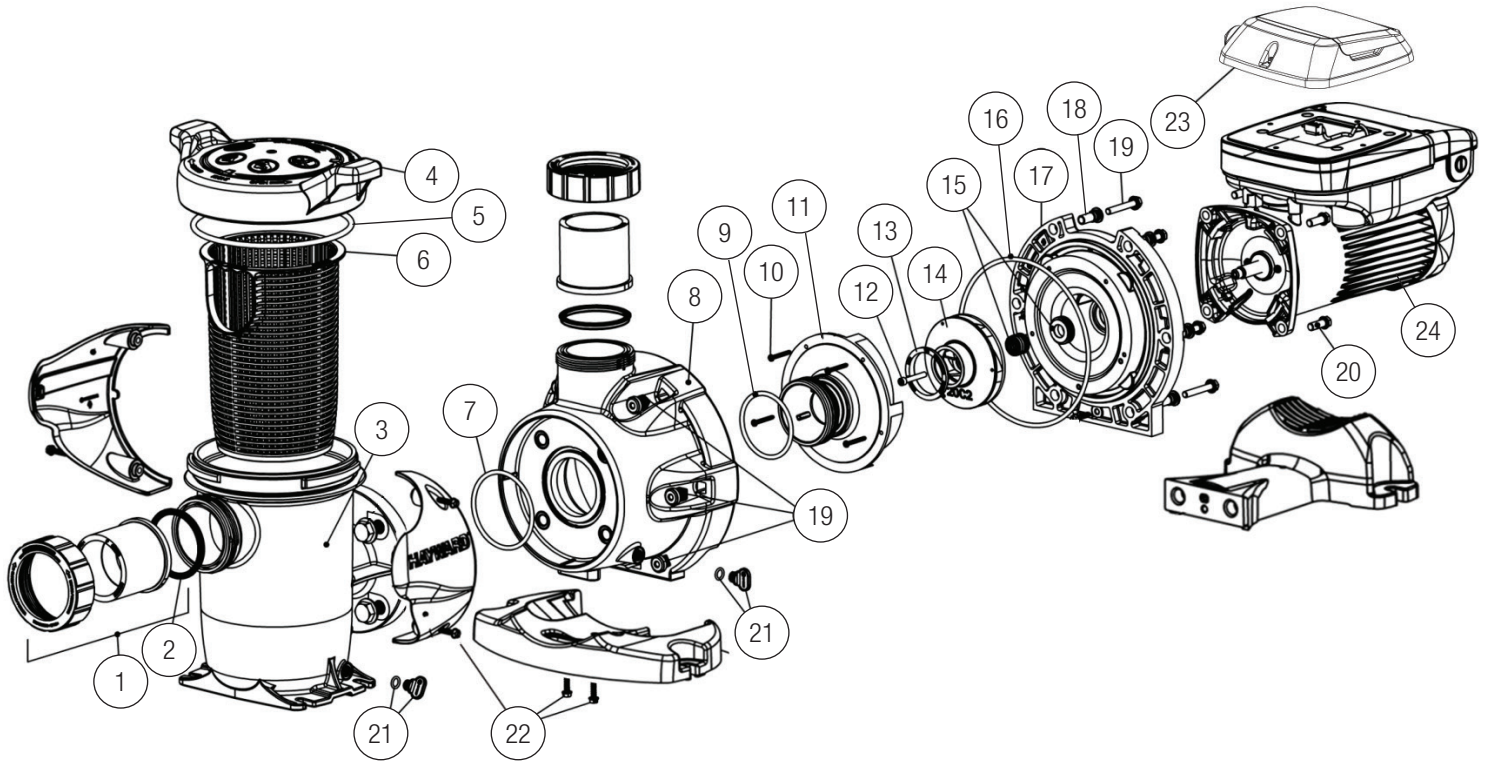

No.	Part Number	Description	Qty.	No.	Part Number	Description	Qty.
1	HCXP3000UNKIT	Union Connector Kit (Includes 2 Nuts, Connectors and Gaskets)	1	14	HCXP3020C	Impeller with Impeller Screw	1
2	HCXP3000UG	Union Gasket	1	15	SPX4000SAV	Shaft Seal Assembly	1
3	HCXP3000H	Strainer Housing with Drain Plug	1	16	HCXP369V70	Pump Housing O-Ring	1
4	HCXP3000DLS	Strainer Cover Kit (Includes Strainer Cover, Lock Ring and O-Ring)	1	17	HCXP3000E	Seal Plate	1
5	SPX4000S	Strainer Cover O-Ring	1	18	SPX3200Z211	Housing Insert/Seal Plate Spacer Kit	1
6	HCXP3000M	Strainer Basket	1	19	SPX3200Z3	Housing Bolt	1
7	HCXP343V70	Strainer Housing Flange O-Ring	1	20	SPX3200Z5PAK4	Motor Bolt (4 Pack)	1
8	HCXP3000A	Pump Housing with Drain Plug	1	21	SPX4000FG	Drain Plug with O-Ring	1
9	HCXP338V60	Diffuser O-Ring	1	22	SPX1600Z52	Base Screws (2 Pack)	1
10	SPX3200Z8	Diffuser Screws (5 Pack)	1	23	VSDISPLAYX1	Display Terminal Assembly	1
11	HCXP3000B	Diffuser	1	24	HCXP3020Z1VSPE	Power End Assembly (Includes #10-18, 2 ea. #19-20, #21, #27 and Motor Assy)	1
12	SPX3200Z1	Impeller Screw	1	-	SPX3400DRKIT	Remote Mounted Display Kit	1
13	HCXP3000R	Impeller Ring	1	-	SPX3200DRCC	Communication Cable Kit	1



HAYWARD®

Supplier's Declaration of Conformity

47 CFR § 2.1077 Compliance Information

Unique Identifier: MaxFlo®, Super Pump, and TriStar® Series Variable Speed Pumps
FCC Responsible Party: Hayward Industries, Inc.
One Hayward Industrial Drive Clemmons, NC 27012 www.hayward.com

Contains FCC ID: RNW-BT923

Contains IC ID: 5110A-BT923

In order to avoid the possibility of exceeding the FCC radio frequency exposure limits, human proximity to the antenna should not be less than 20 cm during operation.

This device complies with part 15 of the FCC Rules. Operation is subject to the following two conditions: (1) This device may not cause harmful interference, and (2) this device must accept any interference received, including interference that may cause undesired operation.

Changes or modifications not expressly approved by Hayward could void the user's authority to operate this equipment.

NOTE: This equipment has been tested and found to comply with the limits for a Class B digital device, pursuant to Part 15 of the FCC Rules. These limits are designed to provide reasonable protection against harmful interference in a residential installation. This equipment generates, uses and can radiate radio frequency energy and, if not installed and used in accordance with the instructions, may cause harmful interference to radio communications. However, there is no guarantee that interference will not occur in a particular installation. If this equipment does cause harmful interference to radio or television reception, which can be determined by turning the equipment off and on, the user is encouraged to try to correct the interference by one or more of the following measures:

- Reorient or relocate the receiving antenna.
- Increase the separation between the equipment and receiver.
- Connect the equipment into an outlet on a circuit different from that to which the receiver is connected.
- Consult the dealer or an experienced radio / TV technician for help.

This Class B digital apparatus complies with Canadian ICES-003.
Cet appareil numérique de la classe B est conforme à la norme NMB-003 du Canada.

This device complies with Industry Canada license exempt RSS standard(s). Operation is subject to the following two conditions: (1) This device may not cause interference, and
(2) This device must accept any interference, including interference that may cause undesired operation of the device.

Le présent appareil est conforme aux CNR d'Industrie Canada applicables aux appareils radio exempts de licence. L'exploitation est autorisée aux deux conditions suivantes:

- (1) l'appareil ne doit pas produire de brouillage, et
- (2) l'utilisateur de l'appareil doit accepter tout brouillage radioélectrique subi, même si le brouillage est susceptible d'en compromettre le fonctionnement.



HAYWARD®

HAYWARD® Pool Products Limited Warranty

Hayward Pool Products, Inc., warrants the components of this product to be free from defects in materials and workmanship during the warranty period. Please visit <https://hayward.com/support/resources/warranty> for product warranty details.

The limited warranty excludes damage from freezing, negligence, improper installation, improper use or care, Acts of God or as specified in installation and operations manual. Parts that fail or become defective during the warranty period shall be repaired or replaced, at our option.

Proof of purchase is required for warranty service. In the event proof of purchase is not available, the manufacturing date of the product will be the sole determination of the purchase date.

To obtain warranty service, please contact the place of purchase or the nearest Hayward Authorized Service Center. For assistance on your nearest Hayward Authorized Service Center, please visit us at <https://hayward.com/dealerlocator>.

Hayward shall not be responsible for cartage, removal, repair or installation labor or any other such costs incurred in obtaining warranty replacements or repair.

The Hayward Pool products warranty does not apply to components manufactured by others. For such products, the warranty established by the respective manufacturer will apply.

The express limited warranty above constitutes the entire warranty of Hayward Pool Products with respect to its pool products and is in lieu of all other warranties expressed or implied, including warranties of merchantability or fitness for a particular purpose. In no event shall Hayward Pool products be responsible for any consequential, special or incidental damages of any nature.

Some states do not allow a limitation on how long an implied warranty lasts, or the exclusion of incidental or consequential damages, so the above limitation may not apply to you. This warranty gives you specific legal rights, and you may also have other rights, which vary from state to state.

Hayward Industries, 1415 Vantage Park Dr., Suite 400, Charlotte, NC 28203

***Supersedes all previous publications**

Register your product at <https://hayward.com/support/resources/warranty/product-registration>

For further information or consumer
technical support, visit our website at
www.hayward.com



 Hayward is a registered trademark of Hayward Industries, Inc. © 2026 Hayward Industries, Inc.
The Bluetooth® word mark and logos are registered trademarks owned by Bluetooth SIG, Inc. and any use of such marks by Hayward is under license.

All other trademarks not owned by Hayward are the property of their respective owners. Hayward is not in any way affiliated with or endorsed by those third parties. For patent information, refer to www.hayward.com/patents.

USE ONLY HAYWARD GENUINE REPLACEMENT PARTS