



HAYWARD®

We Build Better.™

4.0 HP TriStar® Series

VS Series Pumps with OmniX®

TRUE 4.0 HP PERFORMANCE
WITH BUILT-IN AUTOMATION



TriStar® XL
HCP3040VSP

TriStar®
VSP32940

EXPERT LINE®



ONLY FROM POOL PROS



3+ YEAR PARTS & LABOR WARRANTIES*

*When sold by a Totally Hayward® Partner. Exclusions, other terms and conditions may apply — visit hayward.com/expert for details.

POWERFUL. RELIABLE. CONNECTED.



True 4.0 HP performance engineered with the industry's most innovative features delivers maximum versatility to your pool. These pumps feature the new integrated universal display that seamlessly connects with Omni®, OmniX and competitive automation systems. With its simple and intuitive operation, comprehensive control is delivered with enhanced programming and advanced diagnostics. No matter the situation, this pump is the solution: new construction, drop-in replacement, or commercial applications.



INTUITIVE INTERFACE

Designed with usability and flexibility in mind, the new universal display offers an improved user experience with advanced functionality.



UNIVERSAL COMMS

Seamlessly connect to most pool automation systems with integrated universal communication technology.



POWERFUL PERFORMANCE

Elevated flow rates that are ideal for feature-rich pools including bubblers, sheers, laminars and more.

CONTROL FROM ANYWHERE WITH OMNI X APP AND GATEWAY*

- » Complete control from your smart device
- » Configure your equipment quickly and intuitively
- » Integrated user management tools for homeowners and pool professionals.

*Gateway sold separately



LEARN MORE





TriStar® XL
HCP3040VSP



SWIMMING POOL
AND SPA PUMP 193E
ALSO CERTIFIED TO
NSF/ANSI/CAN 50

- » **Superior Performance** — Flow rates optimized for the most demanding applications.
- » **Total Control** — Advanced UI delivers simple and intuitive programming, along with the flexibility of Omni or OmniX automation.
- » **Drop-In Replacement** — Communicates with most Pentair and Jandy® pool controllers for retrofit on automated pads.
- » **Removable Strainer Housing** — TriStar XL model features a removable strainer housing that can be plumbed separately for maximum installation flexibility.
- » **Includes Standard Union Connections** — Enables quick connections for installation, maintenance, and repair.
- » **Totally Enclosed Fan-Cooled (TEFC) Motor** — Maximized reliability through resistance to water, chemicals, and heat.

SOLUTION FOR MULTIPLE APPLICATIONS

- ✓ Standalone or Automated Operation
- ✓ Large & Demanding Builds
- ✓ New Construction or Replacement
- ✓ Commercial Duty



UNIVERSAL AUTOMATION

Seamlessly connects with Hayward and competitive systems.



SUPERIOR PERFORMANCE

Ideal for feature-rich pools that demand high flow rates.



MOBILE APP CONTROL

Remote access for total control to program and diagnose issues from anywhere.



SIMPLE AND INTUITIVE OPERATION

One consistent user interface and experience across all products with the built-in universal display.

WORKS GREAT WITH OUR OTHER
INDUSTRY-LEADING PRODUCTS FOR
HIGH-FLOW APPLICATIONS



3-INCH VALVE



RDX™ DRAIN



GVA-24 ACTUATOR



OMNI X GATEWAY

SPECIFICATIONS

MODEL NUMBER	PUMP FAMILY	TOTAL HP	AUTOMATION COMPATIBILITY	INPUT VOLTAGE	CURRENT RATING	WEF	PLUMBING CONNECTIONS	STRAINER VOLUME	WARRANTY
HCP3040VSP	TriStar® XL	4.0	OmniX / OmniLogic / Universal Comms*	208-230V	17.1-15.5A	6.0	2.5 x 3" Unions	273 CU. IN.	4 years**
VSP32940	TriStar®	4.0	OmniX / OmniLogic / Universal Comms*	208-230V	17.1-15.5A	6.0	2 x 2.5" Unions	137 CU. IN.	3 years

*Universal Comms allows for connectivity to competitive automation systems from Pentair and Jandy®.

**4 Year warranty when installed in a residential application.

TRISTAR XL VS HCP3040VSP PERFORMANCE COMPARISON

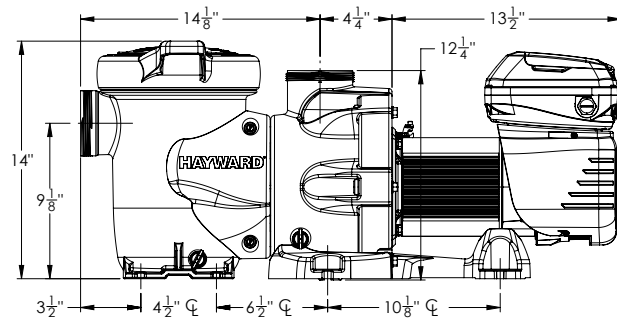
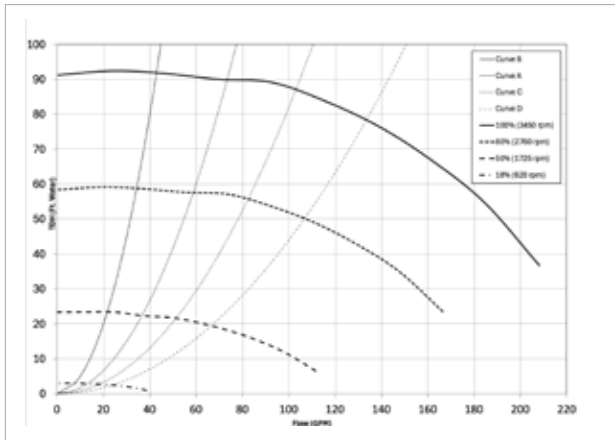

TRISTAR VS VSP32940 PERFORMANCE COMPARISON

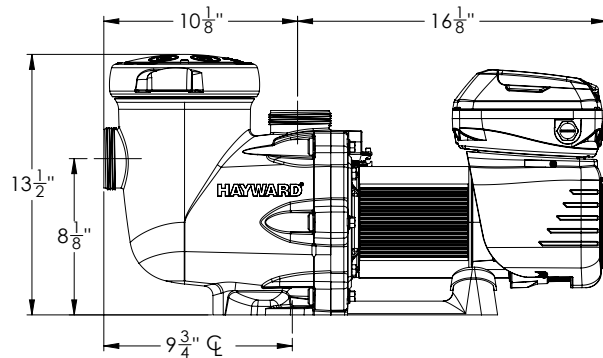
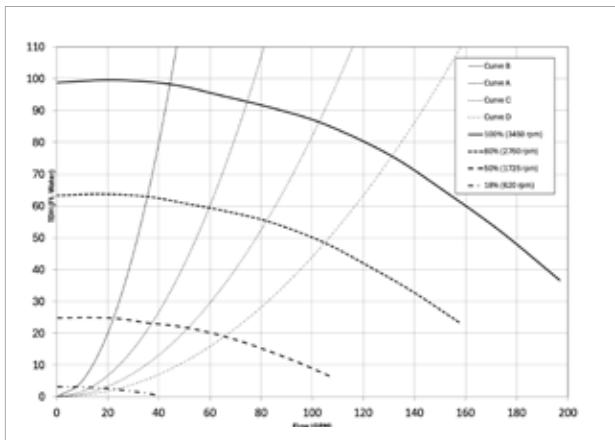

**PROUD
AMERICAN
COMPANY
SINCE 1925**

Founded in Brooklyn, New York in 1925, Hayward has grown from a humble American workshop into a global brand, proudly headquartered in Charlotte, North Carolina. From our earliest valves to today's smart, energy-efficient pool equipment, our mission remains the same: deliver top-quality products, delight customers, and create lasting memories around the water.

» hayward.com » 1-888-HAYWARD

Pumps » Filters » Heaters » Water Quality » Automation » Lighting » Water Features » Cleaners » White Goods

Hayward, Hayward & Design, the H logo, Expert Line, Omni, OmniX, OmniLogic, TriStar, Totally Hayward, Hayward We Build Better, and We Build Better, are registered trademarks of Hayward Industries, Inc. All other trademarks not owned by Hayward are the property of their respective owners. Hayward is not in any way affiliated with or endorsed by those third parties. ©2025 Hayward Industries, Inc.

HAYWARD®
We Build Better.™

LITTSXLVS4HP25